

EQUIPPED WITH A VENTURI SPREADER THIS AL.60 IS ONE OF SEVERAL AGRICULTURAL VERSIONS OF THE PLANE.

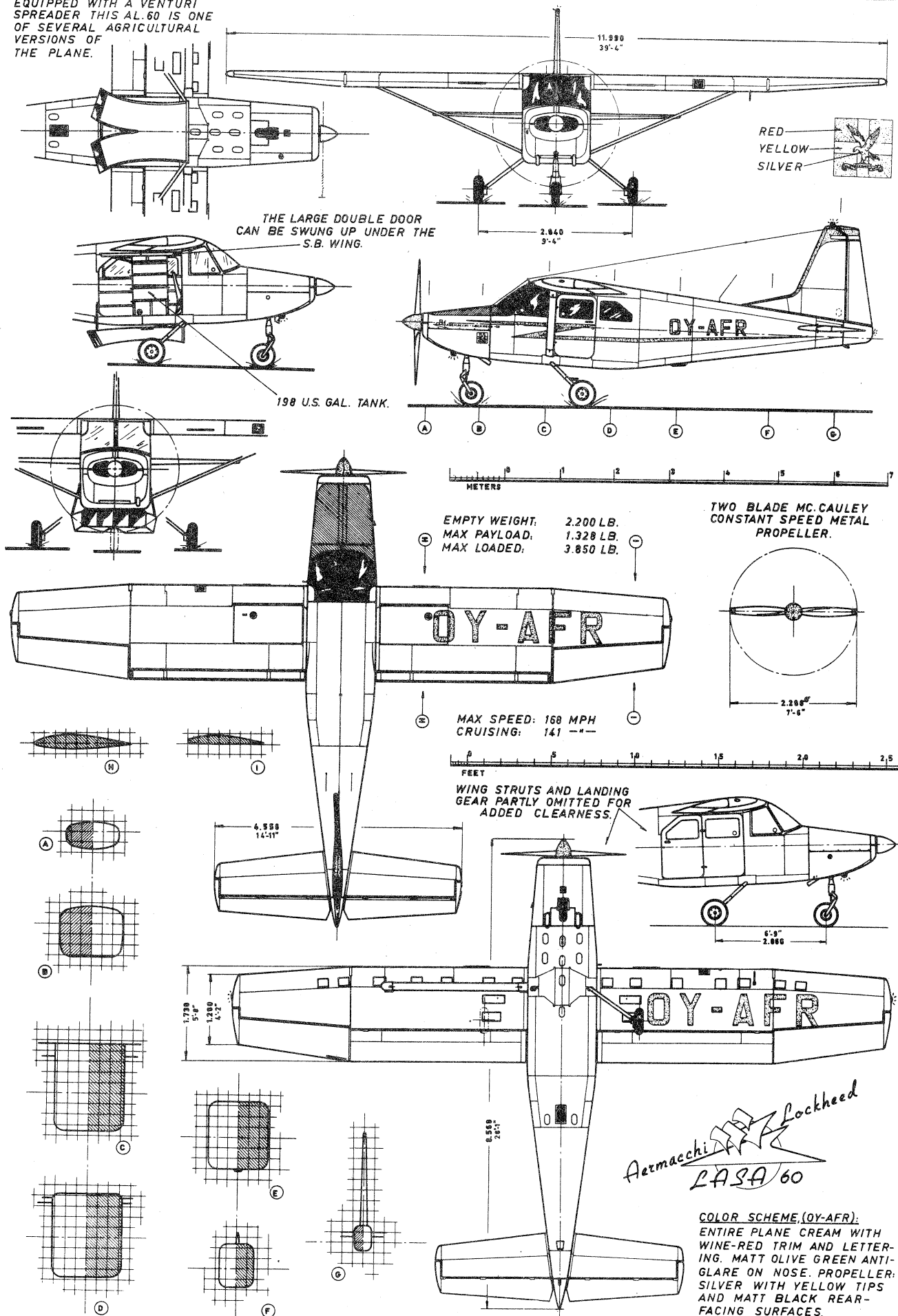

AERMACCHI LOCKHEED LASA 60

LATEST AL.60 VERSION IS THE AL.60-C-4 (BELOW) WHICH IS CURRENTLY BEING TESTED BY THE ITALIAN AIR FORCE

THE AL.60-C-4 FEATURES A CONVENTIONAL TAIL WHEEL LANDING GEAR THE MAIN WHEEL OF WHICH IS SHOWN IN DETAIL BELOW

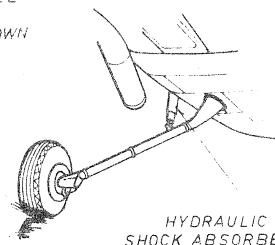
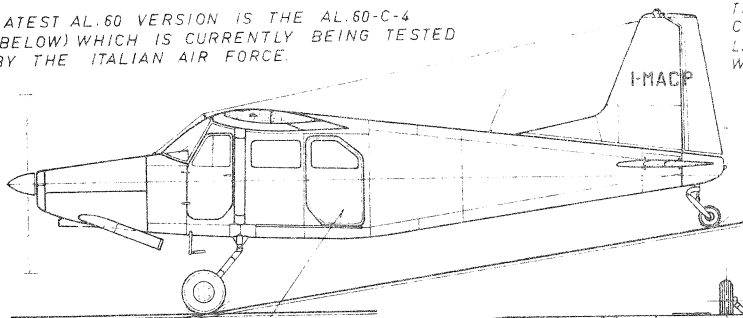

HYDRAULIC SHOCK ABSORBER.

THIS NEW SLIDING DOOR MAKES THE -C-4 SUITABLE FOR PARACHUTE JUMPING AND LAUNCHING OF SUPPLIES FROM THE AIR ETC.

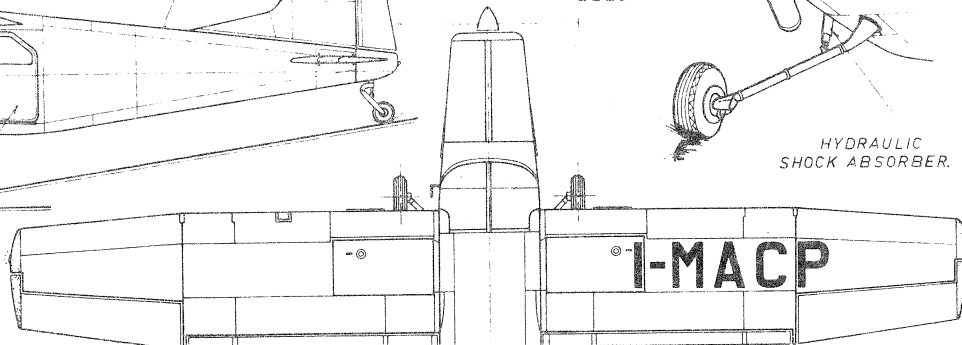

SKIS FITTED TO MAIN WHEEL OF STANDARD AL.60.

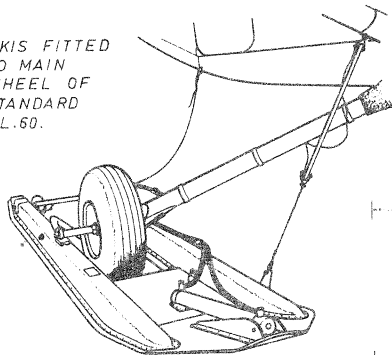

COLOR SCHEME (AL.60-C-4 PROTOTYPE):
ENTIRE PLANE: MATT GREEN-BROWN ARMY STANDARD PAINT WITH BLACK LETTERING.
ORANGE DAY-GLO ON TIPS OF WING AND STABILIZERS.
BLACK PROPELLER WITH YELLOW TIPS.
POLISHED ALUMINUM SPINNER.

AL.60-C-4 DATA:
WEIGHT, EMPTY: 2,344 LB.
— " —, LOADED: 4,200 LB.
MAX. SPEED: 170 MPH
CRUISING: 144 MPH
RANGE: 445 MLS.
SERVICE CEILING: 19,200 FT.

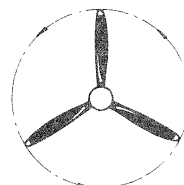

THREE-BLADE PIAGGIO CONSTANT SPEED METAL PROPELLER (AL.60-C-4)

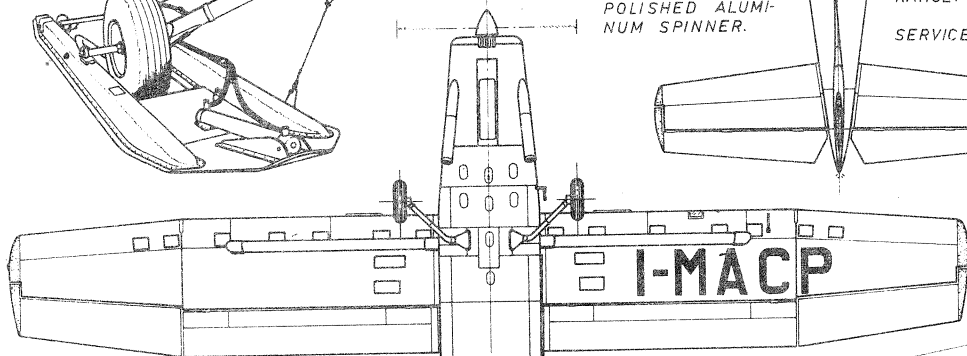

POWER PLANT:

ONE 6-CYL. AIR COOLED CONTINENTAL IO-470-R RATED AT 250 HP OR A SUPERCHARGED CONTINENTAL TS10-470-B RATED AT 260 HP.

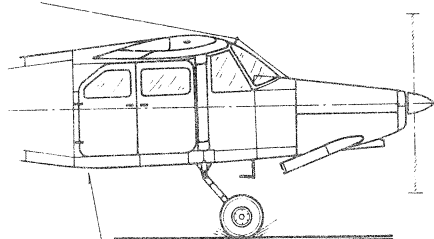

NOTE: DOOR HINGED AFT.

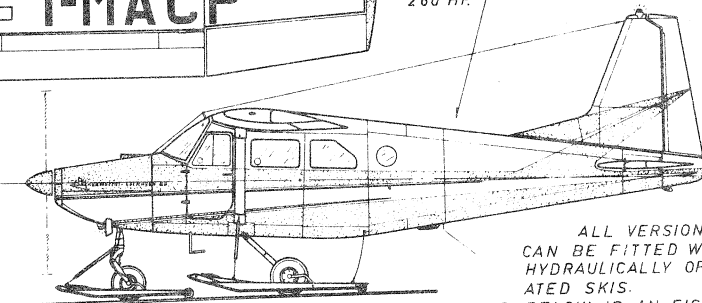

ALL VERSIONS CAN BE FITTED WITH HYDRAULICALLY OPERATED SKIS.

ABOVE AND BELOW IS AN EIGHT-SEAT AL.60-B-2 EQUIPPED WITH THIS TYPE OF LANDING GEAR.

THIS PLANE IS FINISHED IN THE CURRENT COLOR SCHEME. IVORY BASE WITH RED OR BLUE TRIM. TRIM CAN ALSO BE IN TWO TONES OF GREEN OR IN BLUE WITH A GOLD CENTRAL STRIP.

NOSE WHEEL WITH HYDRAULIC SKI-GEAR INSTALLED

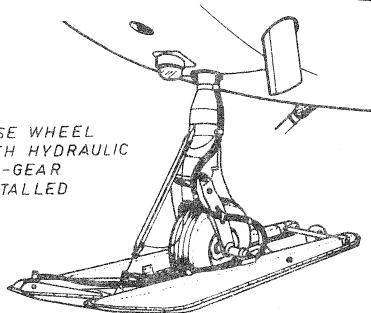

MORE POWER FOR THE NEW AL.60-C-4 IS PROVIDED BY A SIX CYL. SUPERCHARGED PIAGGIO-LYCOMING G50-480-B1B6 ENGINE GIVING 340 HP AT TAKE OFF

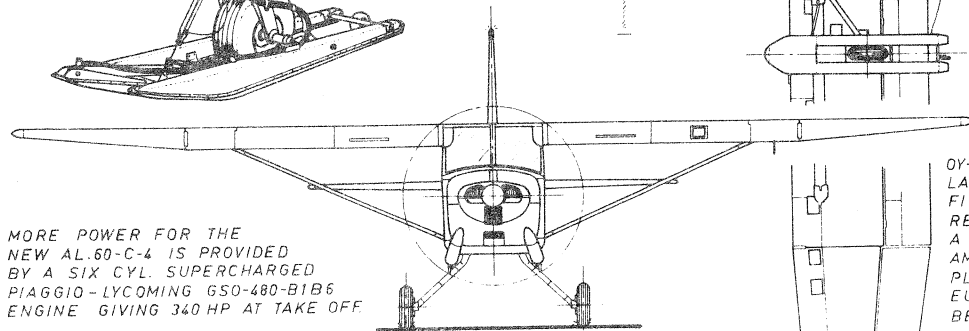

0Y-AFR (OPPOSITE PAGE) IS AN EARLY LASA 60 BELONGING TO THE DANISH FIRST AID ORGANIZATION FALCK'S REDNINGSKORPS, WHICH OPERATES A FLEET OF 1-, 2- AND 4-ENGINE AMBULANCE- AND LIGHT TRANSPORT PLANES SERVING ALL PARTS OF EUROPE INCLUDING COUNTRIES BEHIND THE IRON CURTAIN