

ALBATROS TRIPLANE

SPECIFICATIONS

TOP SPEED _____ 132 MPH
 WING SPAN _____ 25'-8"
 LENGTH _____ 23'-11"
 HEIGHT _____ 8'-9"
 HORSEPOWER _____ 160
 CYLINDERS _____ 6
 ENGINE MFR. _____ MERCEDES

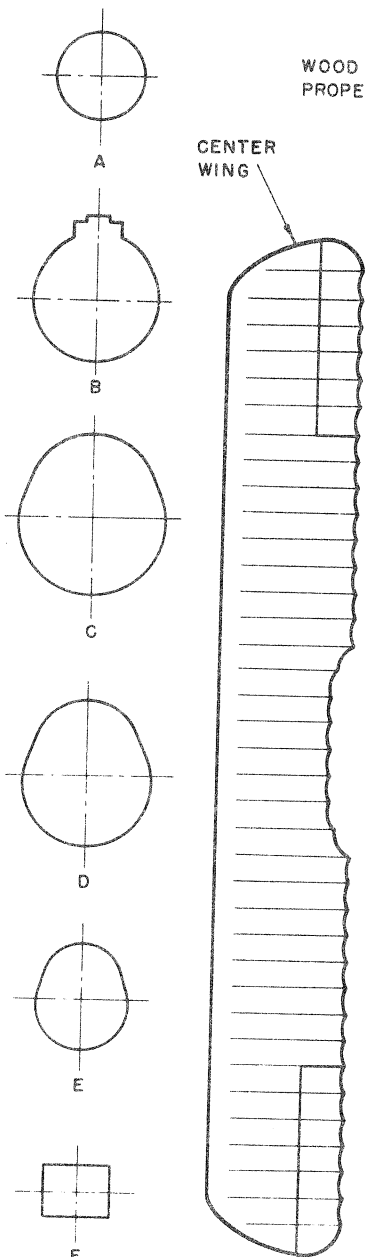
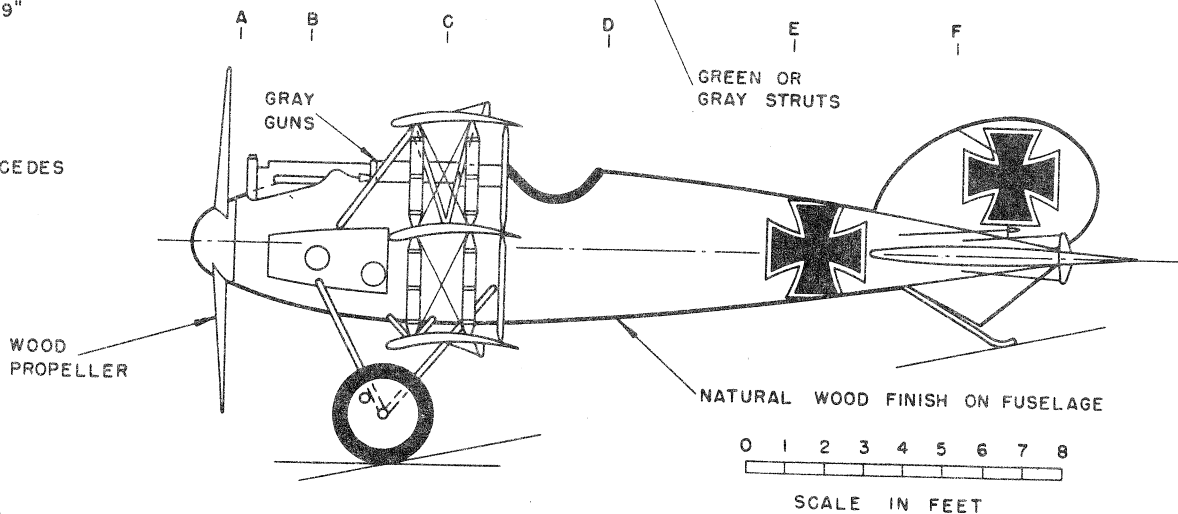
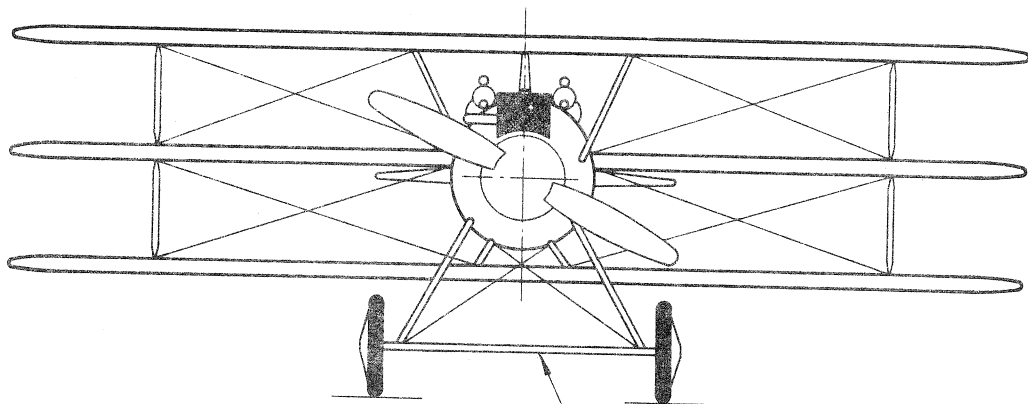

Germany's famous Albatros Werke broke its tradition of biplane designs and produced a beautiful triplane in 1917 . . . apparently in an attempt to equal the success of the Sopwith and Fokker three deckers. However, the sleek, bullet nosed scout was not used in great numbers at the front.

Using the standard Albatros D-3 and D-5 construction, the Triplane had a semi-monocoque wood-covered fuselage and fabric-covered wood structure wings and tail.

Although its speed was fairly high maneuverability was not in accordance with the expectations of the designers. The exceptionally wide tread of the landing gear suggests that ground handling characteristics may have been poor.

Armament consisted of the standard twin Spandau machine guns although at times only one gun was fitted which placed it below the accepted armament standards of the period.

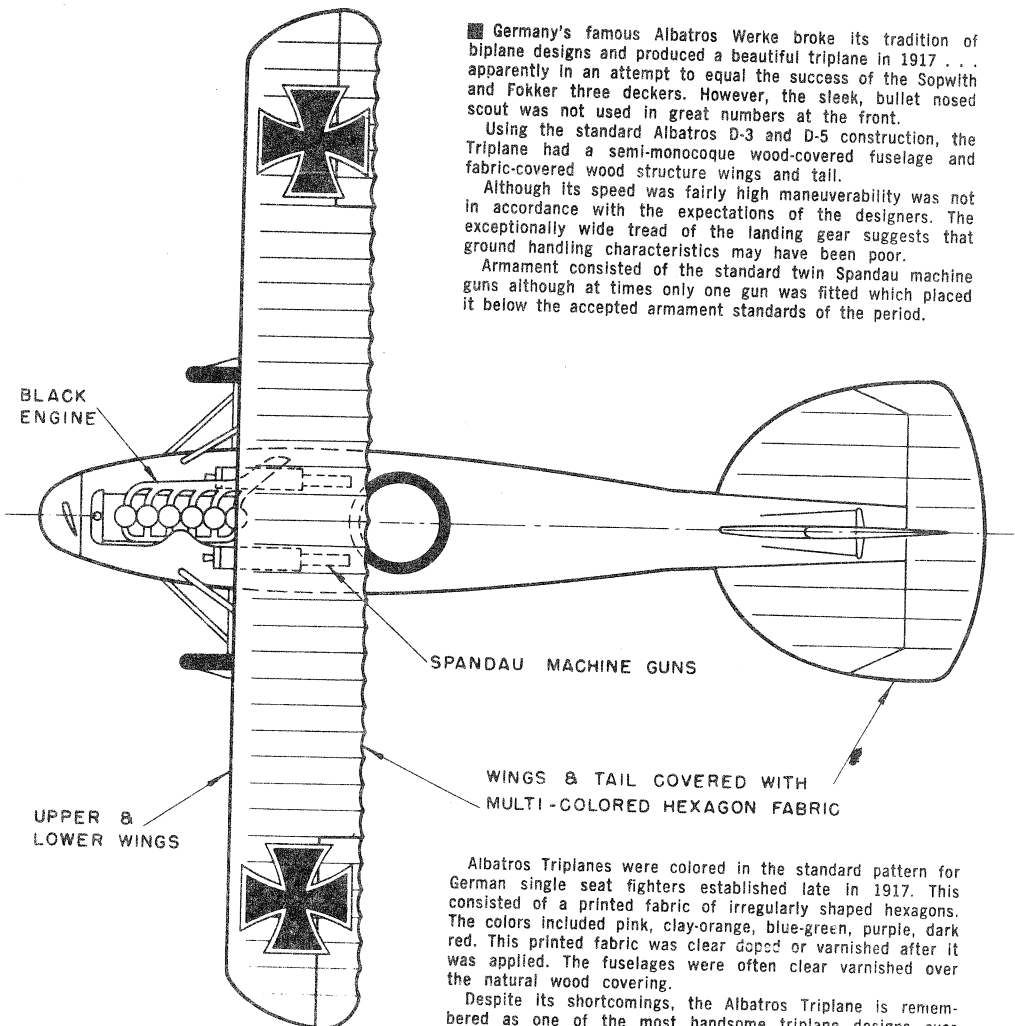

Albatros Triplanes were colored in the standard pattern for German single seat fighters established late in 1917. This consisted of a printed fabric of irregularly shaped hexagons. The colors included pink, clay-orange, blue-green, purple, dark red. This printed fabric was clear doped or varnished after it was applied. The fuselages were often clear varnished over the natural wood covering.

Despite its shortcomings, the Albatros Triplane is remembered as one of the most handsome triplane designs ever conceived.