

**GENERAL SPECIFICATIONS, F2A-3  
BASED ON VF-2 AVERAGE OPERATIONAL FIGURES**

- WEIGHT EMPTY 4,216.5 lbs.
- USEFUL LOAD 2,420.5 lbs.
- GROSS WEIGHT 6,637.0 lbs.
- WING AREA 208.9 sq. ft.
- WING LOADING 31.7 lbs./sq. ft.
- POWER LOADING (1200 h.p.) 55.5 lbs./h.p.
- TOP SPEED 290 mph at 16,500 ft.
- CRUISING SPEED 160 mph
- LANDING SPEED 73 mph
- RATE OF CLIMB, INITIAL 2,000 ft./min.
- FUEL CAPACITY 38 gals. (fuselage)  
64 gals. (wings)  
9 gals.
- OIL CAPACITY 965 miles
- CRUISING RANGE 25,000 feet
- SERVICE CEILING 34,200 feet
- ABSOLUTE CEILING
- POWER, WRIGHT R-1820-40, 1,000 hp at 2,350 rpm  
1,200 hp max. at takeoff & emergency military
- ARMAMENT, COLT BROWNING, 2 .50 cal. in fuselage  
500 rounds each  
2 .50 cal. wing guns  
800 rounds each
- BOMB RACKS, CABLE OPERATED MARK XLI OR XLIH  
116 lb. BOMB PER RACK - NORMAL

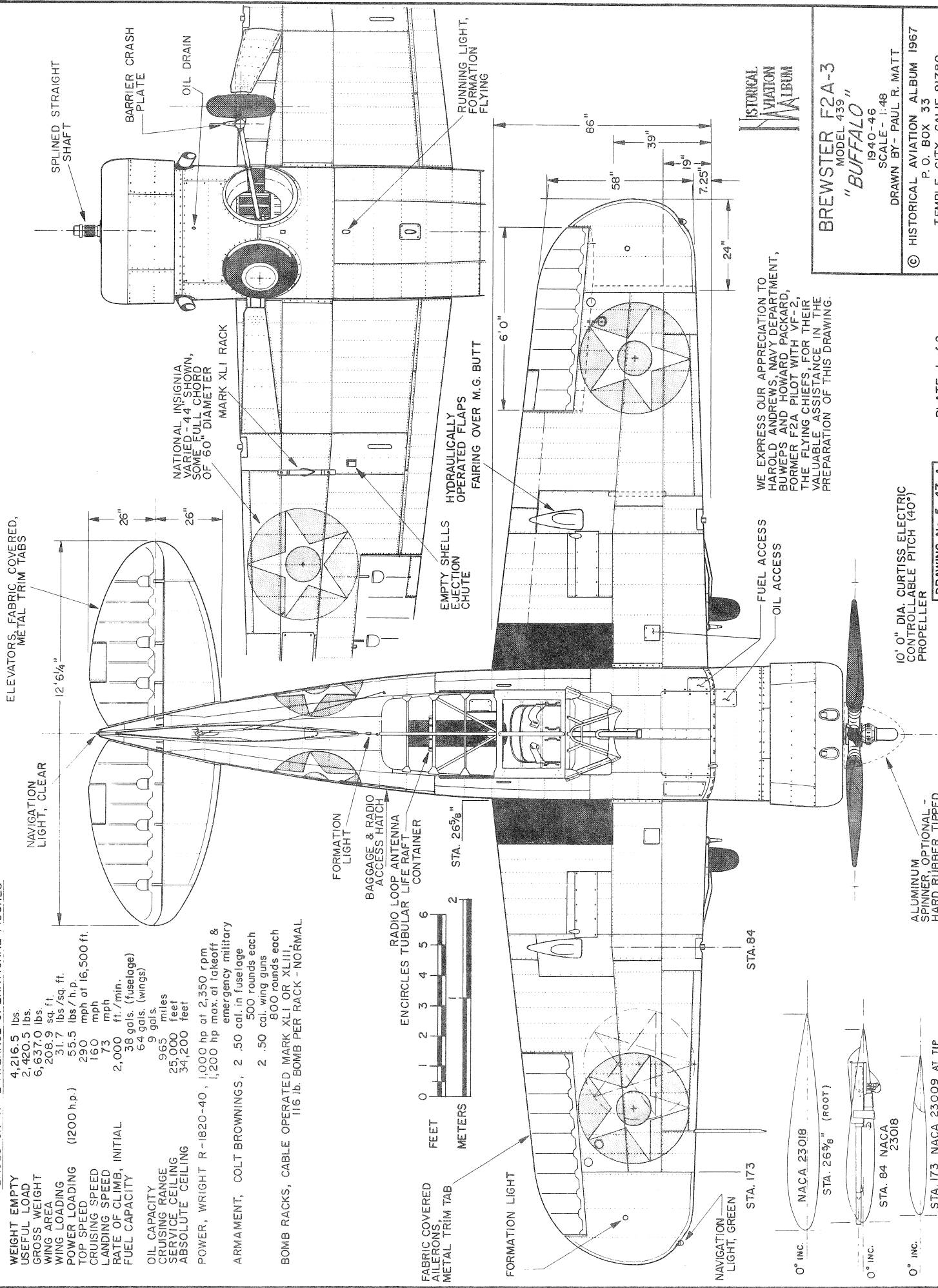

WE EXPRESS OUR APPRECIATION TO HAROLD ANDREWS, NAVY DEPARTMENT, BUWEPs AND HOWARD PACKARD, FORMER F2A PILOT WITH VF-2, THE FLYING CHIEFS, FOR THEIR VALUABLE ASSISTANCE IN THE PREPARATION OF THIS DRAWING.



**BREWSTER F2A-3**  
MODEL 439  
"BUFFALO"  
1940-46  
SCALE - 1:48  
DRAWN BY - PAUL R. MATT  
© HISTORICAL AVIATION ALBUM 1967  
P. O. BOX 33  
TEMPLE CITY, CALIF. 91780

10' 0" DIA. CURTISS ELECTRIC CONTROLLABLE PITCH (40°)  
ALUMINUM SPINNER, OPTIONAL - HARD RUBBER TIPPED

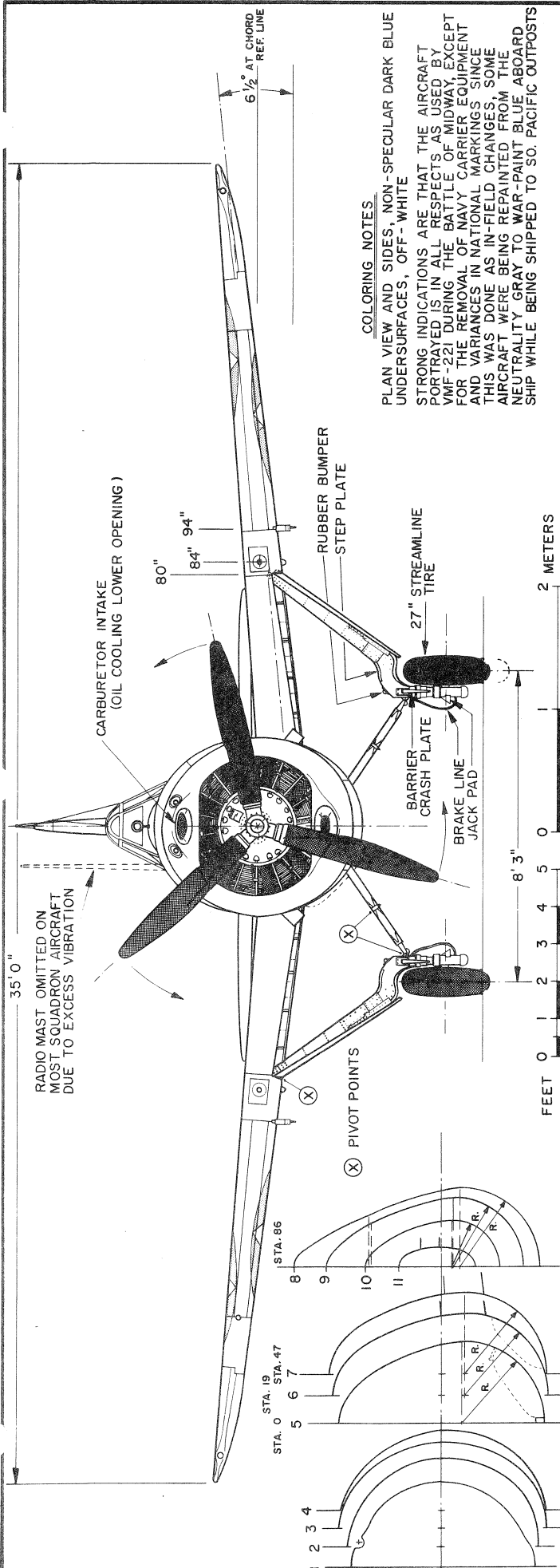

**COLORING NOTES**

PLAN VIEW AND SIDES, NON-SPECULAR DARK BLUE UNDERSURFACES, OFF-WHITE

STRONG INDICATIONS ARE THAT THE AIRCRAFT PORTRAYED IS IN ALL RESPECTS AS USED BY VMF-221 DURING THE BATTLE OF MIDWAY, EXCEPT FOR THE REMOVAL OF NAVY CARRIER EQUIPMENT AND VARIANCES IN NATIONAL MARKINGS SINCE THIS WAS DONE AS IN-FIELD CHANGES, SOME AIRCRAFT WERE BEING REPAINTED FROM THE NEUTRALITY GRAY TO WAR-PAINT BLUE ABOARD SHIP WHILE BEING SHIPPED TO SO. PACIFIC OUTPOSTS

U.S. NAVY F2A PROCUREMENT

XF2A-1	0451
F2A-1	1386-96
XF2A-2	(0451)
F2A-2	1397-1439
F2A-3	1516-1623
XF2A-4	(1516)
TOTAL 163	

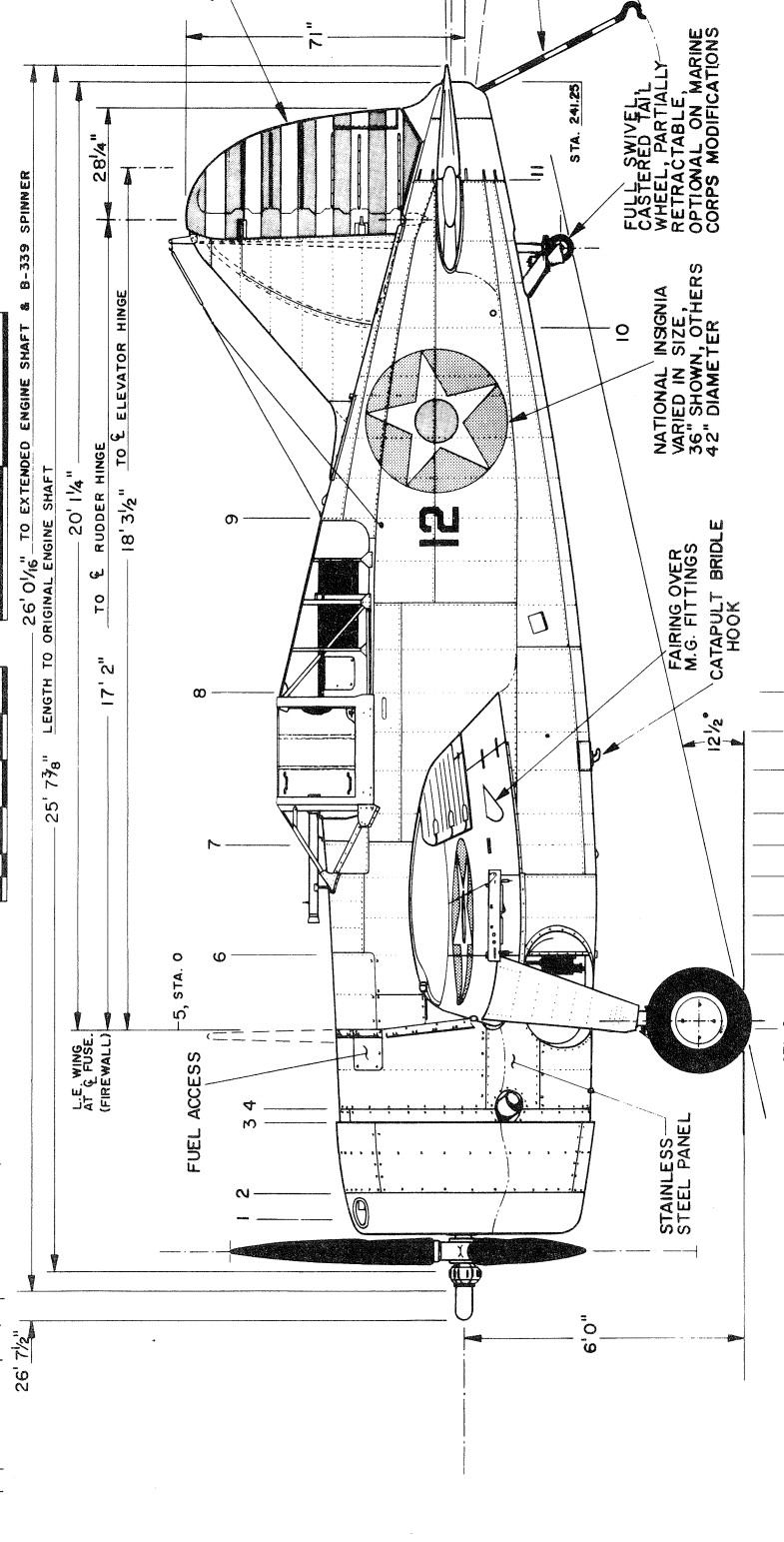

**BREWSTER F2A-3**  
MODEL 439 "**BUFFALO**"

ALTERNATING BLACK AND WHITE STRIPES, CARRIER HOOK REMOVED, ON LAND BASED MACHINES

SCALE - 1:48  
1940 - 46  
DRAWN BY - PAUL R. MATT

© HISTORICAL AVIATION ALBUM 1967  
P. O. BOX 33  
TEMPLE CITY, CALIF. 91780

DRAWING No. 5-47-A

PLATE 2 of 2