

**MARKINGS**

**Prewar:**

Natural metal finish, rudder stripes, U.S. ARMY on lower surface of wing, standard star-in-circle insignia on wings (See left profile and plan view).

**After Pearl Harbor:**

OD finish overall; star-in-circle on fuselage, upper-left and lower-right wing surface. Lower wing surface and under side of belly may or may not have gray camouflage. Early wartime markings showed red center in star, and insignia on all four wing surfaces as on prewar markings. Left profile shows squadron markings on fuselage in white, tail serial numbers yellow.

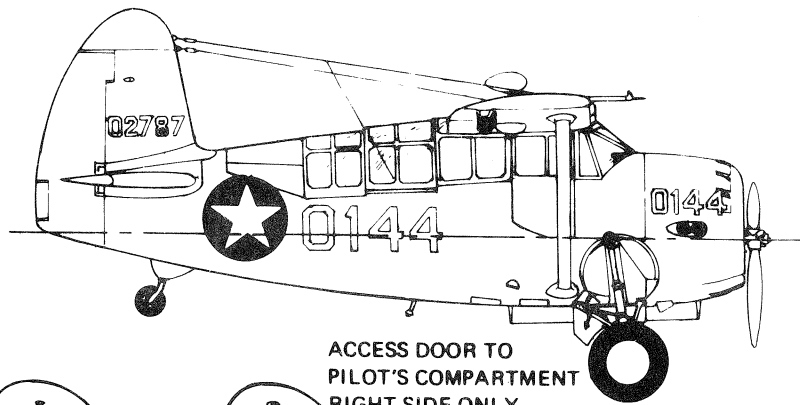

ACCESS DOOR TO PILOT'S COMPARTMENT RIGHT SIDE ONLY

FOLDING DOORS IN FUSELAGE BOTTOM FOR USE OF CAMERA

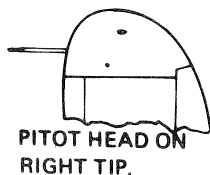

PITOT HEAD ON RIGHT TIP.

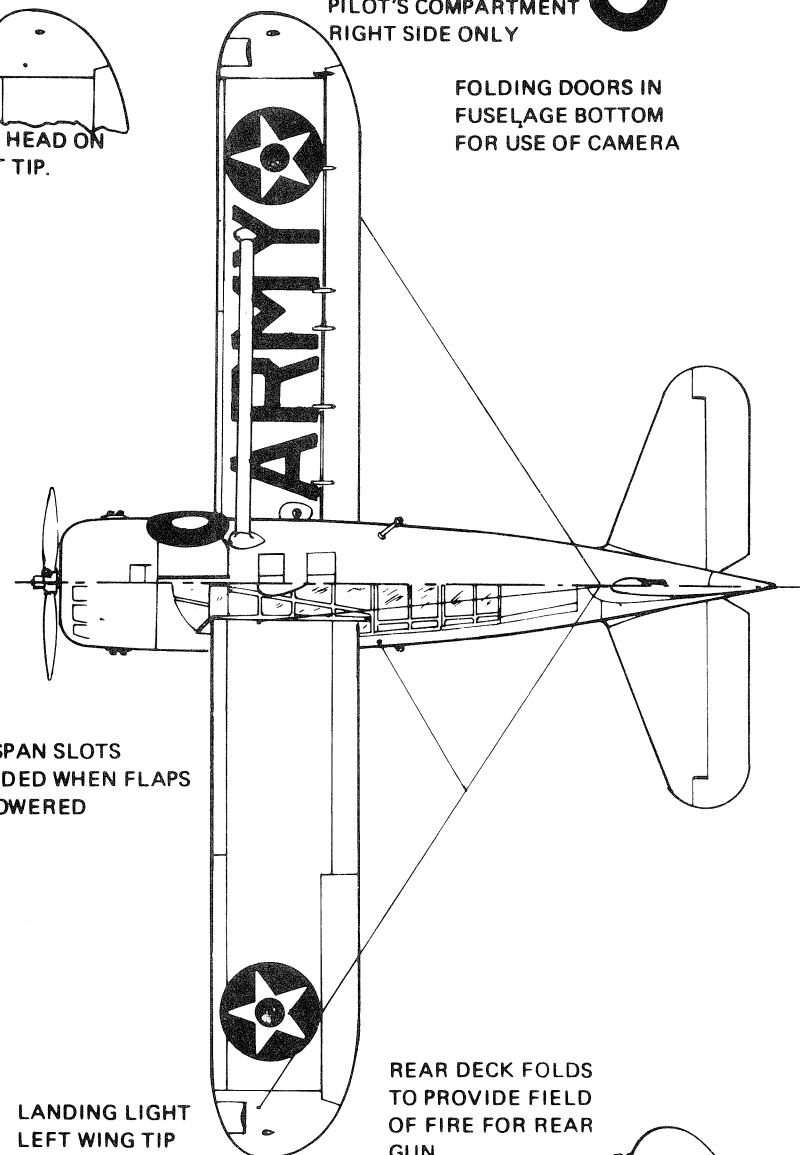
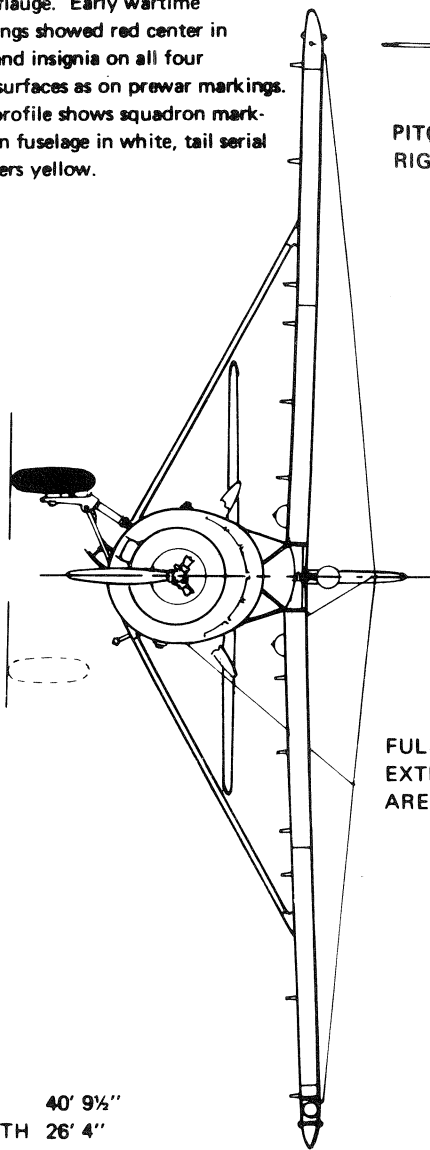

FULL SPAN SLOTS EXTENDED WHEN FLAPS ARE LOWERED

LANDING LIGHT LEFT WING TIP ONLY

REAR DECK FOLDS TO PROVIDE FIELD OF FIRE FOR REAR GUN

SPAN 40' 9 1/2"  
 LENGTH 26' 4"  
 ENGINE P & W R-1340

**ARMAMENT**

One .30 cal. synchronised nose gun, one .30 cal flexible gun.

**CONSTRUCTION**

All-metal construction, flap metal covered; ailerons, rudder and elevator, fabric covered.

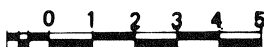
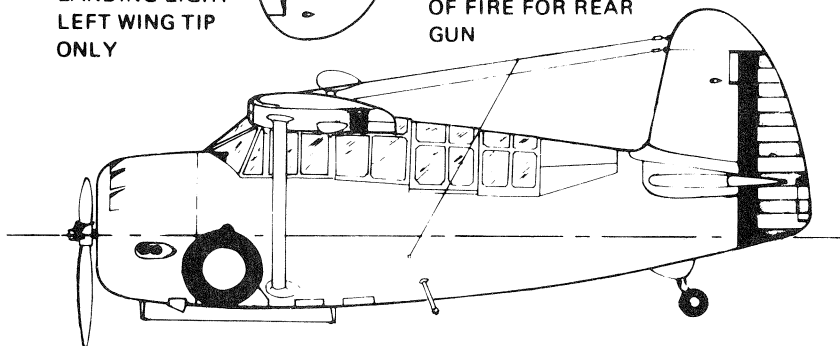

*D. A. R. 4/41*

*Curtiss* O-52 "OWL"