

AIR RAGE INC., 351 FIFTH AVE., NEW YORK 17, N.Y.
 SCALE: 1/4" = 1'-0"
 TYPE: FIGHTER
 COPYRIGHT 1947
 WILLIAM A. WYLAN
 BUILT 25-29 BY Curtiss Aeroplane & Motor Co., Inc.
FUSELAGE DETAILS
P-1 SERIES
 CURTISS U.S. ARMY "HAVOC"

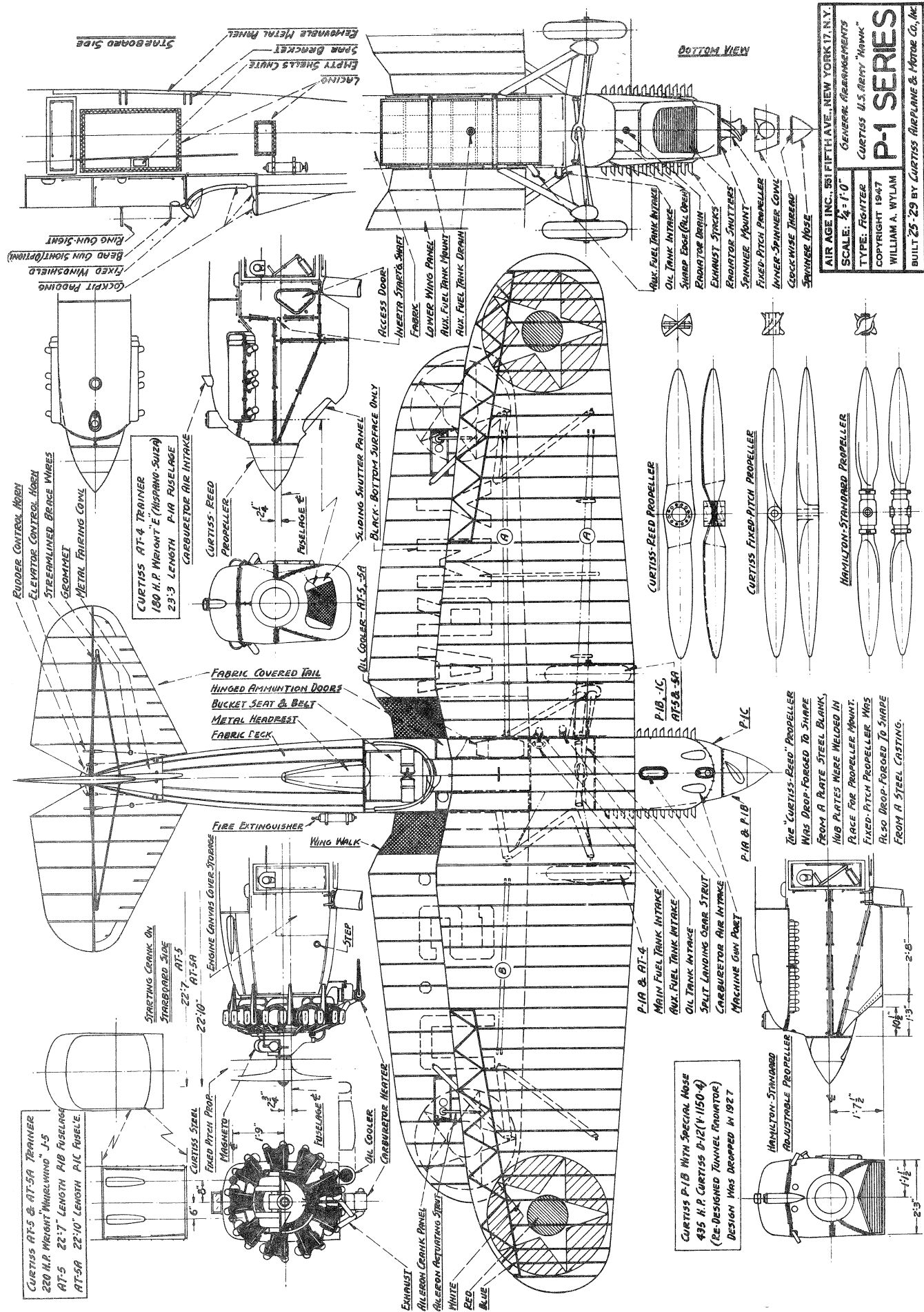

AIR AGE INC., 951 FIFTH AVE., NEW YORK 17, N.Y.
 GENERAL ARRANGEMENTS
 CURTISS U.S. ARMY "HAWK"
P-1 SERIES
 TYPE: FIGHTER
 SCALE: 1/2" = 1'-0"
 COPYRIGHT 1947
 WILLIAM A. WYLAM
 BUILT 25-29 BY CURTISS AIRPLANE & MOTOR CO., INC.

CURTISS P-1B WITH SPECIAL NOSE
 435 H.P. CURTISS D-12 (V-1150-4)
 (RE-DESIGNED TUNNEL PROPATOR)
 DESIGN WAS DROPPED IN 1927

The "CURTISS-REED" PROPELLER
 WAS DROP-FORGED TO SHAPE
 FROM A PLATE STEEL BLANK,
 HUB RATES WERE WELDED IN
 PLACE FOR PROPELLER MOUNT.
 FIXED-PITCH PROPELLER WAS
 ALSO DROP-FORGED TO SHAPE
 FROM A STEEL CASTING.

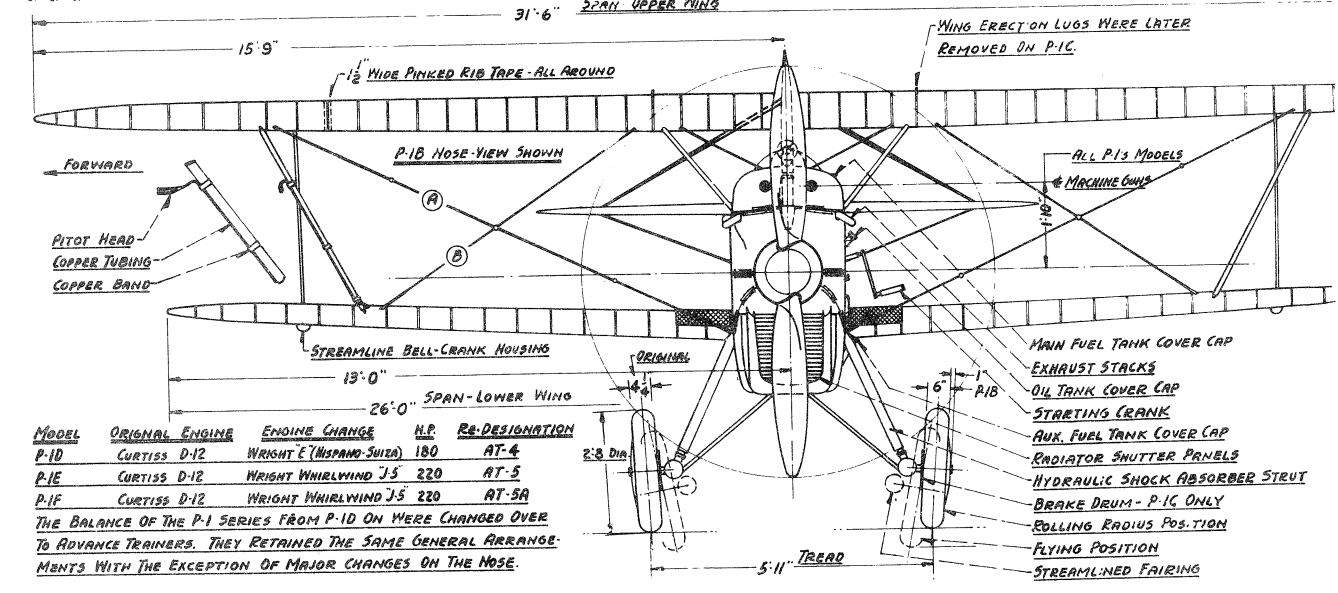
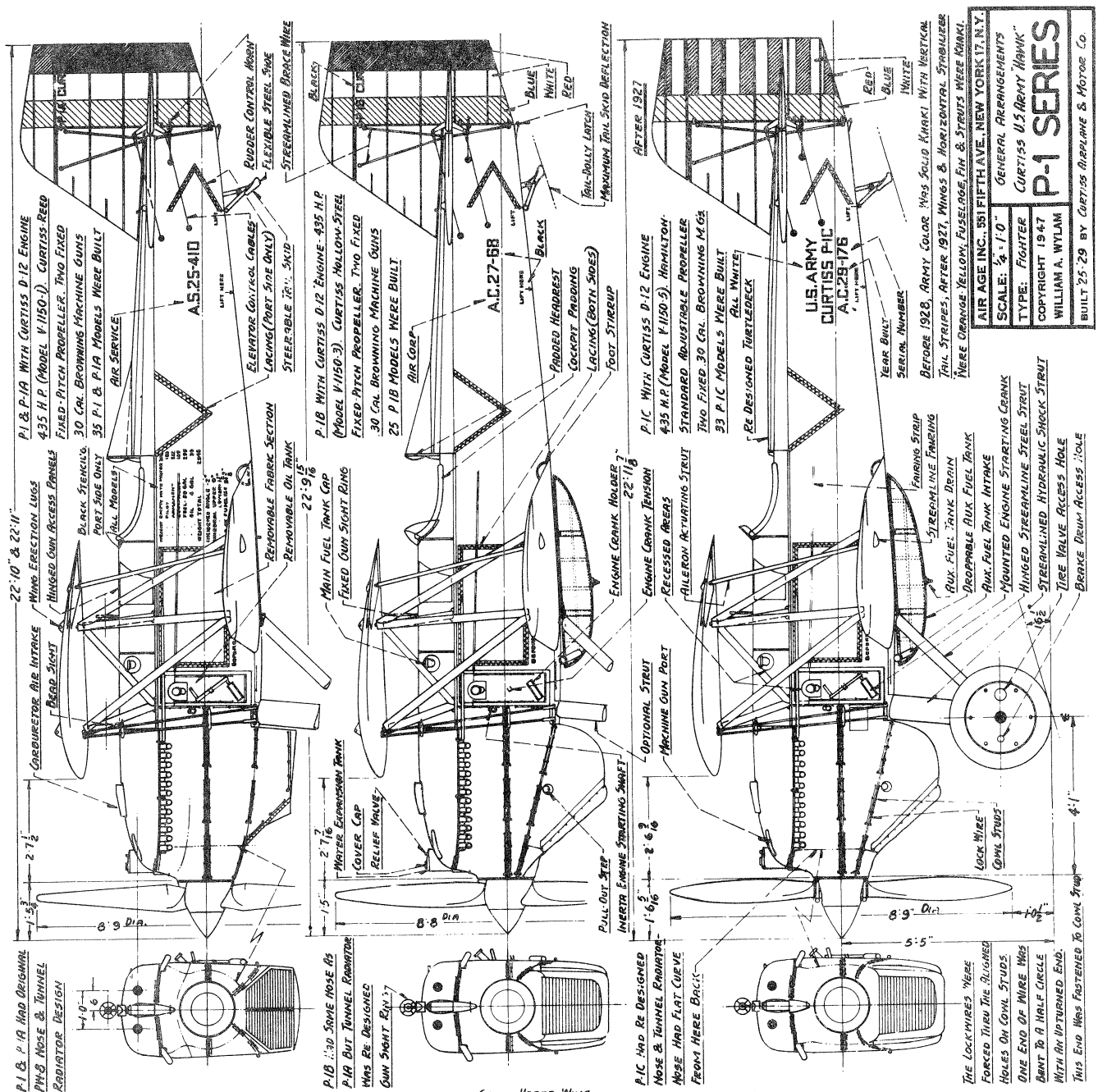

MODEL	ORIGINAL ENGINE	ENGINE CHANGE	H.P.	RE-DESIGNATION
P-1D	Curtiss D-12	Wright E (WSPAW-SUED)	180	AT-4
P-1E	Curtiss D-12	Wright Whirlwind J-5	220	AT-5
P-1F	Curtiss D-12	Wright Whirlwind J-5	220	AT-5A

THE BALANCE OF THE P-1 SERIES FROM P-1D ON WERE CHANGED OVER TO ADVANCE TRAINERS. THEY RETAINED THE SAME GENERAL ARRANGEMENTS WITH THE EXCEPTION OF MAJOR CHANGES ON THE NOSE.