

THRUST PLANE
(PARALLEL TO FUS.
REF. PLANE)

SIZE APPROX	WIDTH	HEIGHT
AB - FRONT CARGO LOAD'G DR	22	38
AC - AUX. EXIT	20	24
AD - CABIN WINDOW	16	12
AE - MAIN CABIN DOOR	84 1/2	70 1/2
AF - PILOT'S AUX. EXIT	23	22
AG - RADIO OP. WINDOW	4 1/4	15 3/16
AH - NAVIGATOR'S DOME	17 3/4	DIA.

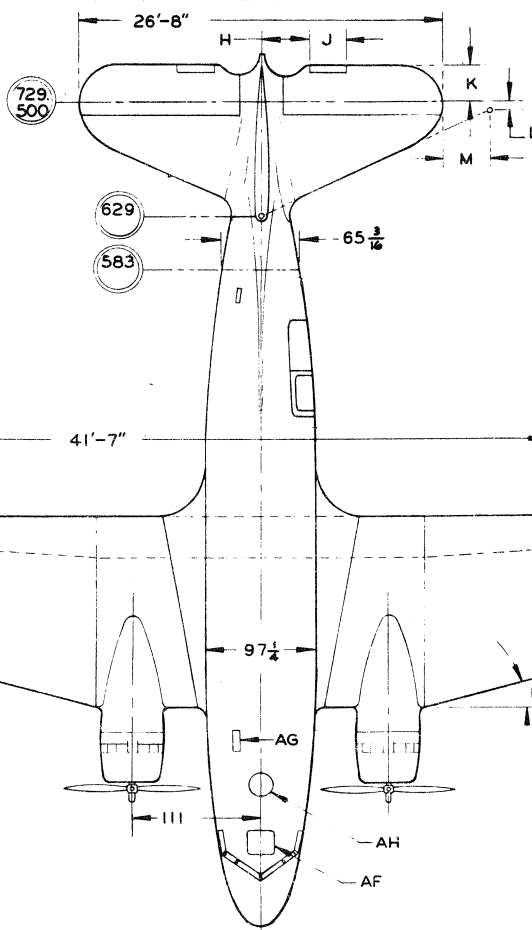

DIMENSIONS

P = 84.500	A = 145.281
S = 70.595	B = 58.125
T = 55.657	C = 45
U = 39.375	D = 32.328
	E = 48.500
	F = 2.438
	G = 35
	H = 41
	J = 32.438
	K = 34
	L = 8.5
	M = 36.8
	N = 40.750

AREAS SQ. FT.

WING, INC'L.AILERONS	987
AILERONS, TOTAL	102.8
AILERON TAB (R.H.ONLY)	1.91
FLAPS, TOTAL	82
VERTICAL TAIL SURFACE	
FIN	37.9
RUDDER	46.6
RUDDER TAB	3

AREAS SQ. FT.

HORIZONTAL TAIL SURFACE	179.2
HORIZ. STABILIZER	95.8
ELEVATORS, TOTAL	83.4
ELEVATOR TABS, TOTAL	3.6

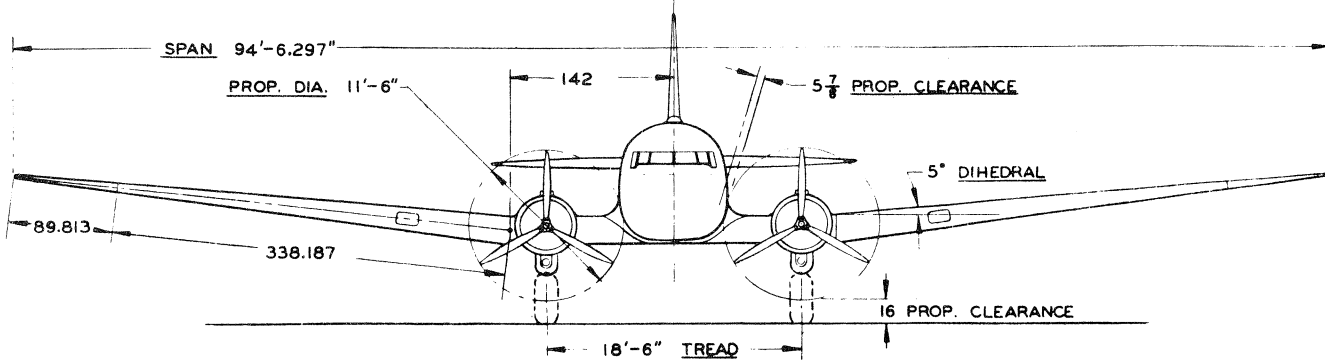

PREPARED BY PRODUCTION ILLUSTRATION - F. KELLOGG - 1-4-44