

Douglas Mailplane M-2

DURING the latter period of the early air-mail-carrying operations by the Postal Department, this airplane did the majority of the mail-carrying after the DH4M type of plane was washed out as obsolete. This plane was chosen after it had fulfilled the required specifications over its competitors in the government mail plane competition, and upwards of fifty were constructed.

This plane is a direct descendant of the Douglas O-2 army observation plane, the only difference being the cockpit arrangement. It is designated in military use type O-2E. The construction is of composite materials. The wings are of wooden construction.

(Continued on page 38)

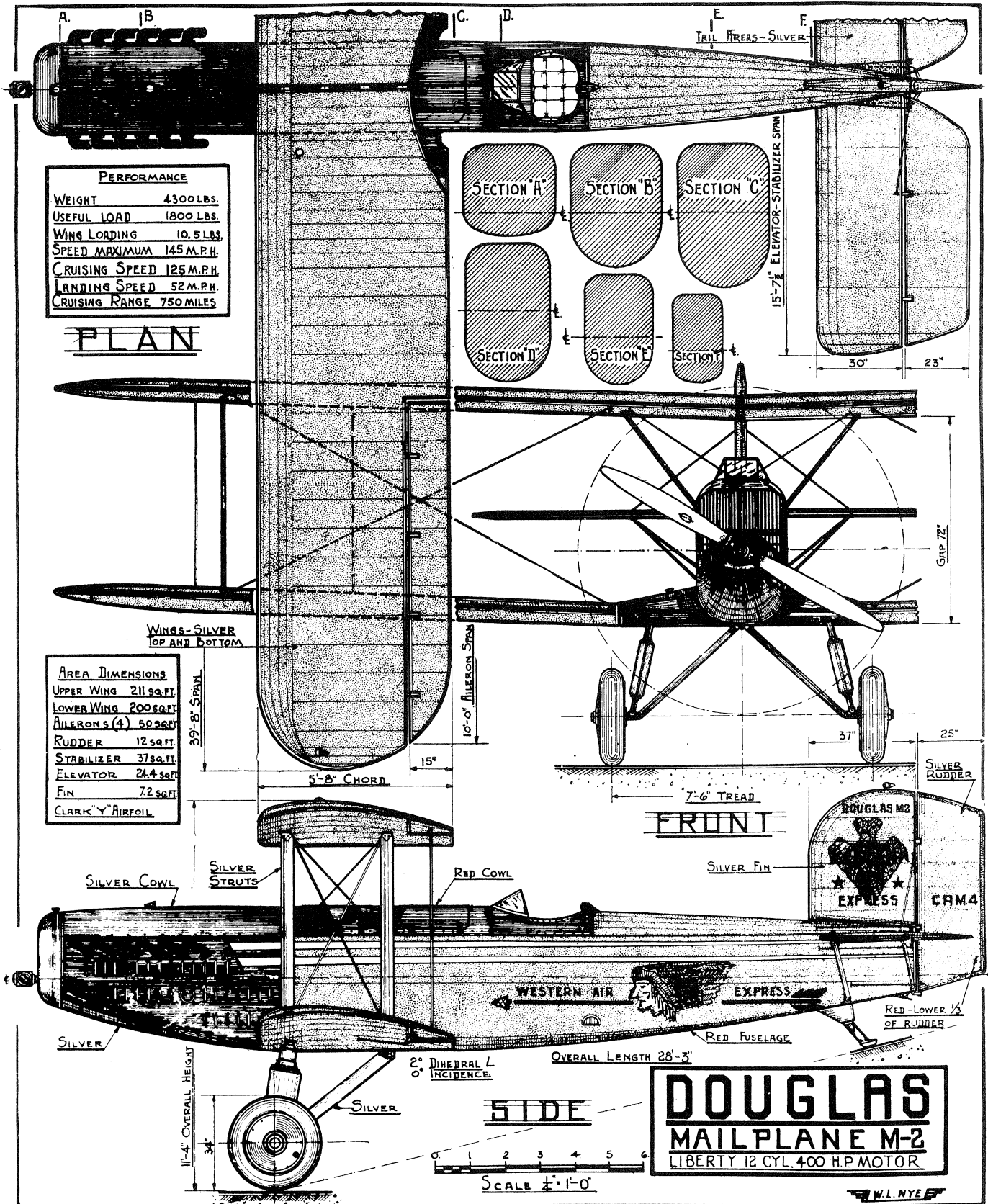

M-2 Mail Plane

WING SPAN 47' (13.71)

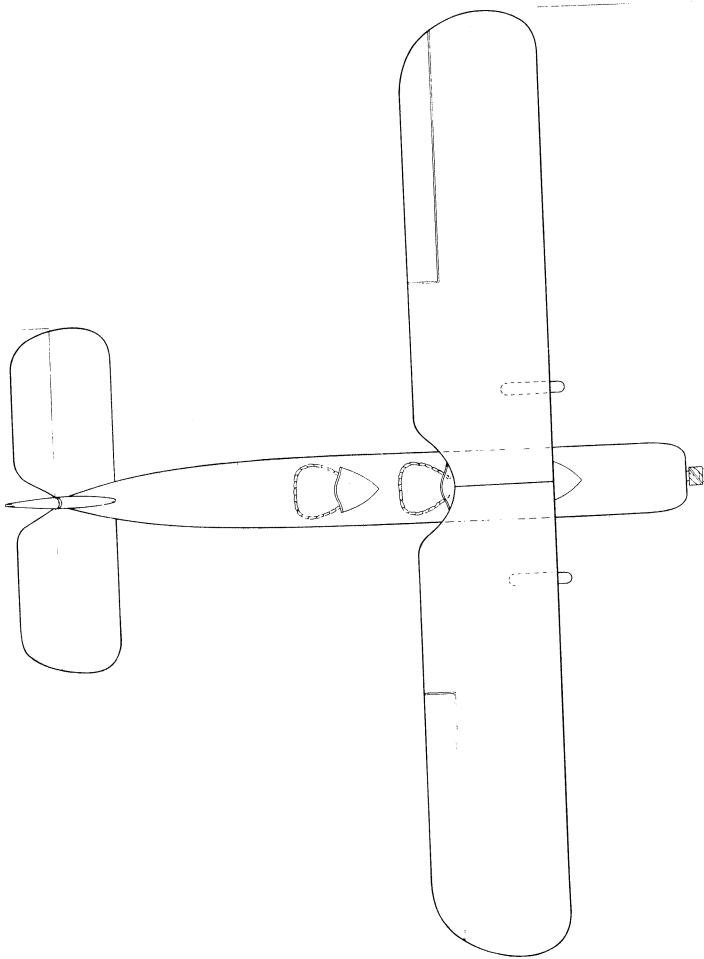

WING SPAN 47' (13.71)

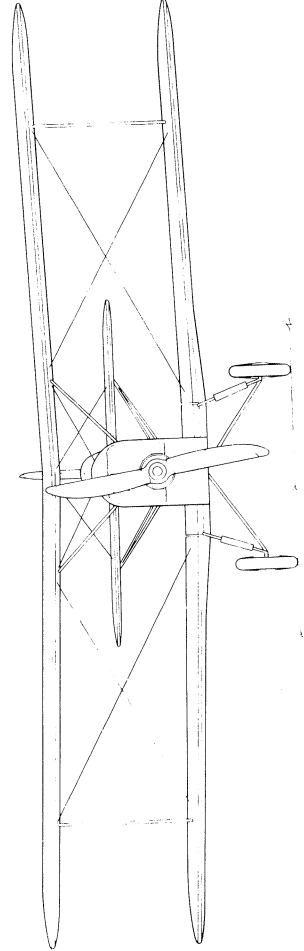

HEAD 3' (0.91)

OVERALL LENGTH 346" (28'-10")

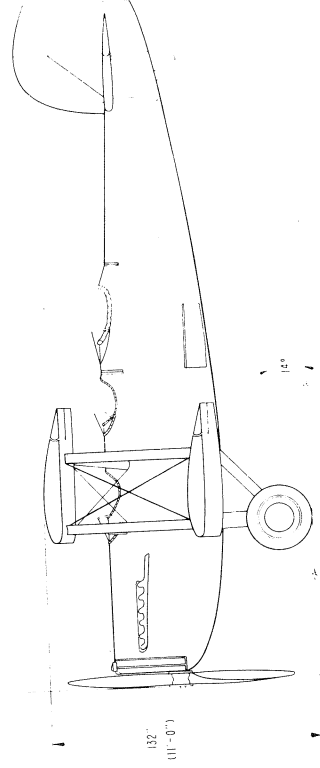

132" (11'-0")

18"