



The model F4F-4 was the version of the Wildcat produced in greatest quantity by Grumman; it differed from the F4F-3 in having folding wings and two more guns. It was powered by a Pratt & Whitney R-1830-86 fourteen-cylinder, 1200 H.P., Twin Wasp engine equipped with a two-stage supercharger. Top speed was 318 m.p.h., range was 1,650 miles at cruise power, rate of climb was 2,050 feet per minute, service ceiling was 34,800 feet. Armament was six .50-caliber guns and two 100-pound bombs could be carried. Grumman built 1,169 F4F-4s (they built 892 other production Wildcats) and Eastern Aircraft built 839 duplicates, designated FM-1, which differed only in having four guns. (Eastern built 5,927 Wildcats in all.)

There were nine different production models of the Wildcat, all similar in appearance. Several versions went to the British Fleet Air Arm who first called them "Martlets."

Land-based Martlets I's were the first American-built fighters in British service to shoot down an enemy aircraft when three of them combined efforts to knock down a Ju. 88 over the Orinacy Islands on Christmas Day, 1940. They went on to escort convoys, fight in the African desert, become famous at Wake Island, supply the fighter strength in the early days in the Pacific, stand by for Douglas's Tokyo raid take-off, fight at Midway, stop the Japs at Guadalcanal, and help the Allies in the Philippines (one took the surrender of a Vichy-French airfield) and supply the fleet's fighter strength until the Hellcat came along. Then they equipped the escort carriers for anti-submarine and invasion work.

COLOR SCHEME

SEA BLUE - SURFACES VISIBLE IN PHOTOGRAPH
 FUEL TANKS AND ALL SURFACES ON WINGS AND ALL SURFACES ON FUSELAGE
 BLUE (BLUE GRAY) - FLAT FINISH ON SIDE SURFACES
 FLAT FINISH ON TOP SURFACES
 FLAT FINISH ON BOTTOM SURFACES AND PANELS ON BOTTOM
 INSIGNIA OUTLINES AND BACK- GROUND DISKS
 GRAY - ENGINE
 GRAY - LANDING GEAR
 GRAY - STEPS, COWL INSIDE
 CHROME - LANDING GEAR STRUT
 ALUMINUM - PROP SHANK COFFERS
 GRAY - ENGINE
 GRAY GREEN - COCKPIT INTERIOR
 50% WHITE, 50% SEA BLUE
 50% WHITE, 50% SEA BLUE
 RED - PITOT SUPPORT
 YELLOW - PROP TIPS (6")

NOTE: AIRPLANE SHOWN IN PHOTOGRAPH HAS NO PANELS OR INSIGNIA
 NOTE: ALL FINISH EXCEPT SEA BLUE COLORS ARE GRADED INTO OUTLINES
 NOTE: ALL FINISH EXCEPT SEA BLUE COLORS ARE GRADED INTO OUTLINES

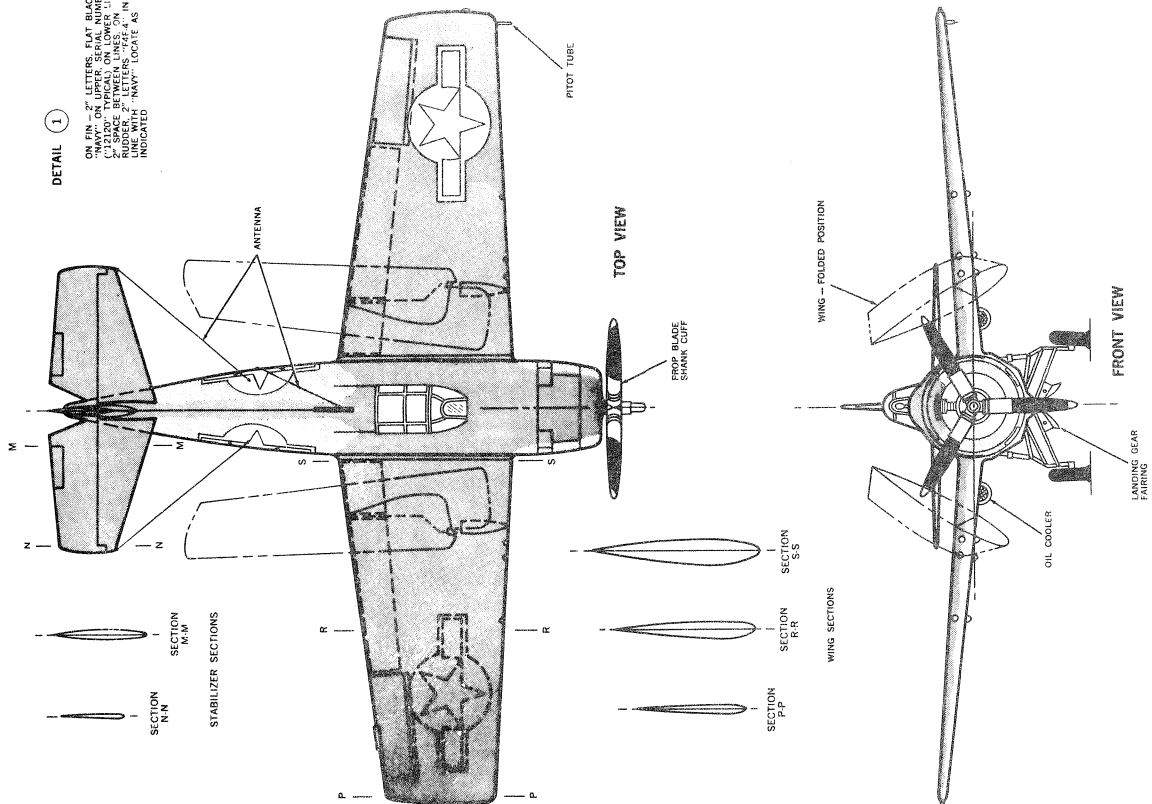

DETAIL 1

ON FIN - 2" LETTERS - FLAT BLACK
 C/12300 OF SYMBOL OR NUMBER
 2" SPACE BETWEEN LINES ON
 INSIGNIA
 LINE WITH "NAVY" LOCATE AS
 INDICATED

Grumman
 AIRCRAFT ENGINEERING CORPORATION
 F4F-4 "WILDCAT"
 U.S. NAVY FIGHTER AIRCRAFT

SEPT 1945

DIMENSIONS
 SPAN 36'
 L.O.A. 28' 10"
 H.O.A. 11' 5"
 H.T. (POSITION) 13' 11" (POSITION)

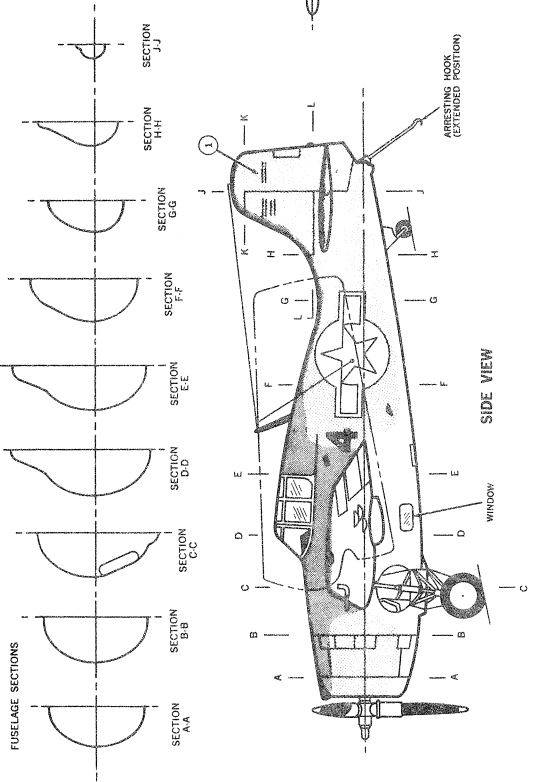

FUSELAGE SECTIONS

SIDE VIEW

ARRESTING HOOK (UPPER POSITION)