



The Skyrocket was a radical design when Grumman proposed it to the Navy; at that time, most fighters were biplanes and single-engine monoplanes were rare. The big single-seater was powered by two Wright R-1820-40, 42 nine-cylinder radial engines. Top speed was 380 m.p.h., range was 1,200 miles at cruise power, rate of climb was 1,000 feet per minute, service ceiling was 33,000 feet. Armament originally specified was two .50-caliber machine guns. Two 165-pound bombs were carried on wing racks and there were five containers in each wing outer panel for small arms. Only one XF5F-1 was built; it flew for the first time on April 1, 1940 and became the first monoplane fighter to land on a carrier deck. It was used in a series of tests and elaborate test program during which numerous modifications were made, including the addition of a second engine and a second propeller. The XF5F-1 was struck from the Navy list after a wheels-up landing in 1944.

**COLOR SCHEME**

- ALUMINUM - ENTIRE AIRPLANE EXCEPT AS NOTED
- PROP HUB, PITOT BOOM, LANDING GEAR STRUT SHAFTS - CHROME YELLOW - UPPER SURFACE OF WING - RED - HISGHIA CENTER DISKS - WHITE - HISGHIA STARS
- INSIGNIA BLUE - INSIGNIA OUTER DISKS
- INSIGNIA BLUE - INSIGNIA INNER DISKS
- INSIGNIA BLUE - INSIGNIA CENTER DISKS
- INSIGNIA BLUE - INSIGNIA "U.S. NAVY" LETTERING AND HAND LETTERING
- GRIP - ENGINE CHAIRCASE AND CYLINDERS - COCKPIT INTERIOR - GRAY-GREEN

STABILIZER SECTIONS

SECTION J-J

SECTION K-K

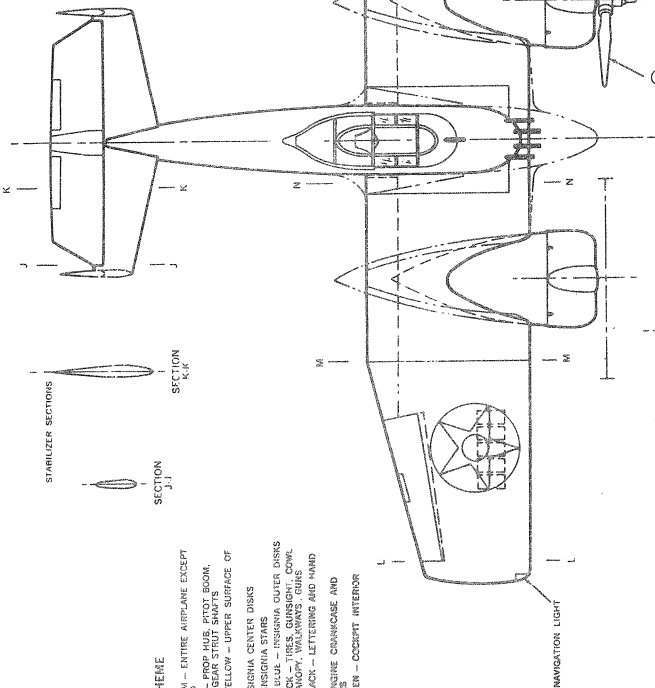

**DETAIL 1**

- INSIGNIA OUTER DISK
- WHITE STAR
- INSIGNIA BLUE OUTER DISK
- INSIGNIA BLUE CENTER DISK
- INSIGNIA BLUE INNER DISK
- NOTE ON MODIFIED VERSION - TOP LEFT WING OUTER DISK RIGHT AND BOTH SIDES OF FUSELAGE

**DETAIL 2**

- PROP HUB, FWD FACE OF BLADES
- INSIGNIA BLUE ON FWD FACE OF BLADES

**DETAIL 3**

- BLACK LETTERS - HISGHIA MODEL AND SERIAL NUMBER (BOTH SIDES - OUTBOARD)
- INSIGNIA BLUE - HISGHIA "U.S. NAVY" (BOTH SIDES OF FUSELAGE)

**TOP VIEW**

WING SECTIONS

TAIL SECTIONS

SECTION F-F

SECTION G-G

SECTION H-H

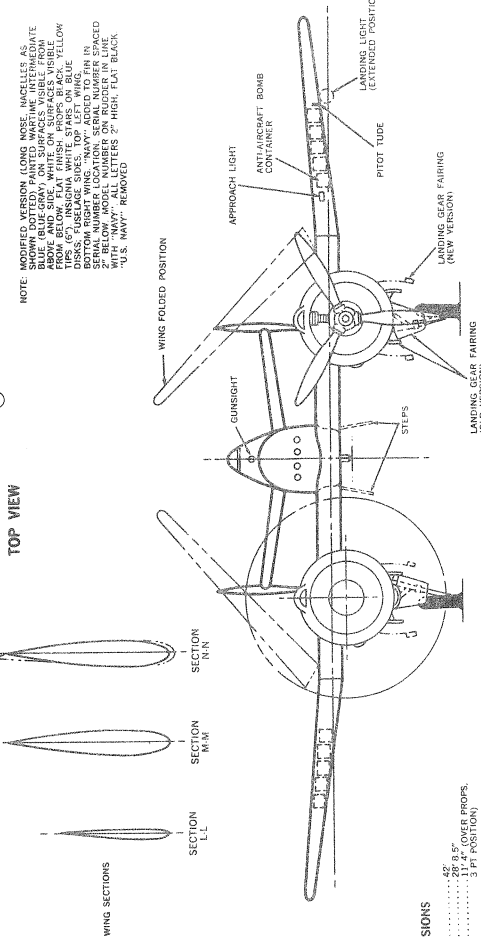

**DIMENSIONS**

- SPAN ..... 42'
- HEIGHT ..... 11.4'
- PROP. POSITION ..... 3 FT

**FRONT VIEW**

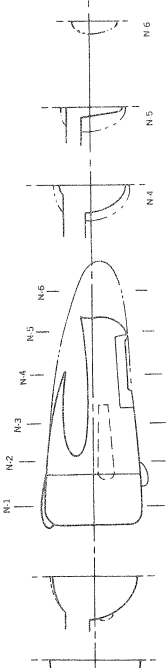
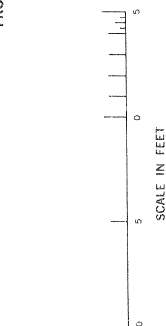

**SIDE VIEW**

TURNOVER STRUCTURE

MANUALLY RETRACTABLE STEPS (BOTH SIDES)

HANDGRIP

ARRESTING HOOK

INSIGNIA

INSIGNIA

INSIGNIA

INSIGNIA

INSIGNIA

INSIGNIA

INSIGNIA

INSIGNIA

INSIGNIA

INSIGNIA

INSIGNIA

INSIGNIA

INSIGNIA

INSIGNIA

INSIGNIA

INSIGNIA

INSIGNIA

INSIGNIA

**Grumman**  
 AIRCRAFT ENGINEERING CORPORATION  
 XF5F-1  
 "SKYROCKET"  
 U.S. NAVY EXPERIMENTAL FIGHTER AIRCRAFT

SEPT 1945