

WEIGHTS AND PERFORMANCES
 (SEAPLANE IN PARENTHESES):
 EMPTY WEIGHT: 5,880 LB (6,285)
 LOADED WEIGHT: 9,975 LB (10,440)

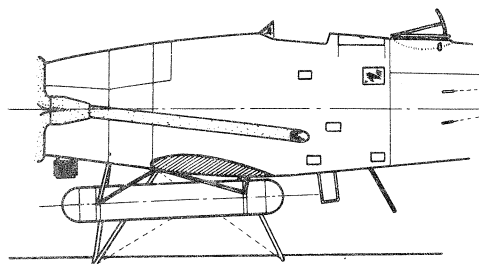

THE PLANES COULD BE FITTED WITH EITHER WHEELS OR FLOATS, --- FLOATS BEING BY FAR THE MOST USUAL.

SEVERAL TRIPS TO ICELAND AND GREENLAND WERE MADE WITH THE "DANTORPS" CARRYING AN EXTRA FUEL TANK IN THE TORPEDO-CARRIERS.

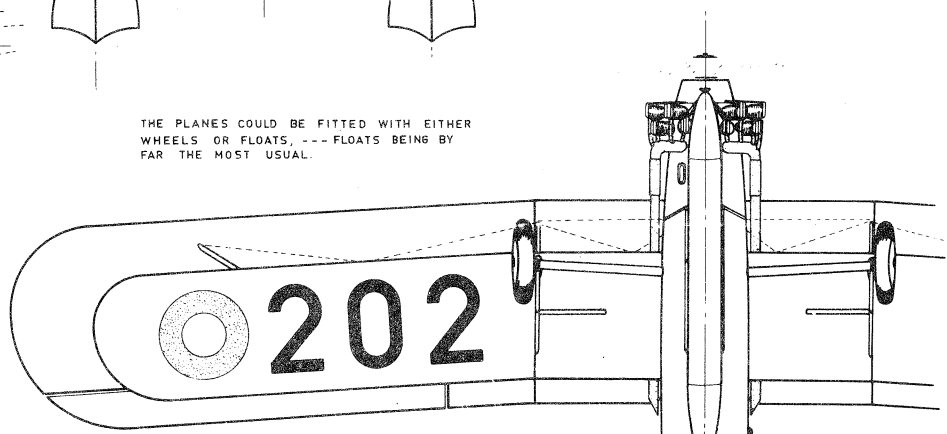

DURING THE WAR BOTH "DANTORPS" ENDED THEIR DAYS AT THE COPENHAGEN NAVAL BASE, HOLMEN, AS VICTIMS OF DANISH FREEDOM-FIGHTERS' FIRE BOMBS, IN ORDER THAT THEY SHOULD NOT FALL INTO THE HANDS OF THE GERMAN OCCUPATION FORCES.

CEILING: 16,000 FT. (12,500)
 RANGE: 840 MILES
 MAX. SPEED: 143 M.P.H. (120)
 CRUISING SPEED: 112 M.P.H. (103)
 TIME TO 9,850 FT.: 14 MIN 10 SEC. (22' 30")

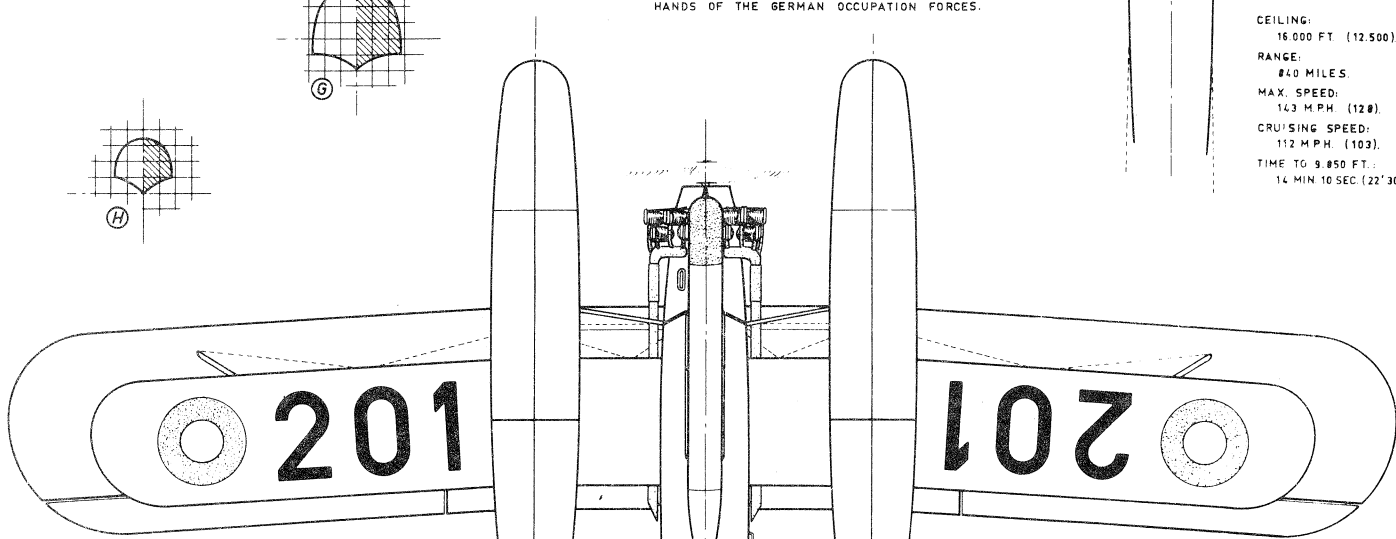
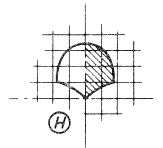
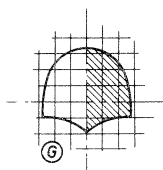
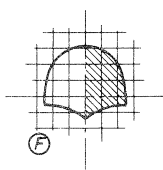

THE "DANTORP" WAS A DANISH VERSION OF RAF'S "HORSLEY" BOMBER EQUIPPED WITH AN 800 HP ARMSTRONG SIDDELEY "LEOPARD" III A RADIAL IN PLACE OF THE 670 HP ROLLS-ROYCE "CONDOR" LIQUID-COOLED ENGINE THAT POWERED THE "HORSLEY". ALSO THE "DANTORP" WAS A THREE-SEATER WHILE THE "HORSLEY" HAD A CREW OF TWO ONLY.

HAWKER, DANTORP⁹
H. B. III

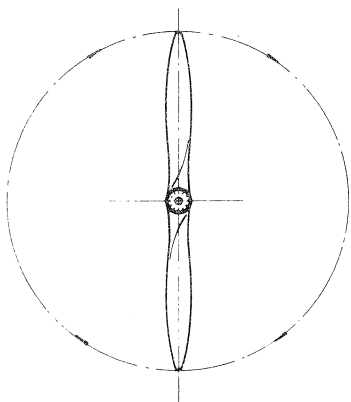

DEFENSIVE ARMAMENT: ONE FIXED AND ONE MOVABLE 8 M/M DANISH MADSEN GUN TYPE M 32/6 AND M 27/a RESP.

COLOR SCHEME:
 ENTIRE PLANE SILVER WITH BLACK LETTERING AND RED-WHITE MARKINGS. TANK-COVERS ON UPPER WING, GREY. PROPELLER: GREY WITH BLACK REAR SURFACE.



TWO HAWKER 'DANTORP' TORPEDO-BOMBERS WERE SUPPLIED TO THE ROYAL DANISH NAVAL AIR SERVICE IN MARCH 1933.

THE DANISH TYPE DESIGNATION WAS H.B. III (HYDRO-BIPLANE TYPE III), AND THE PLANES WERE GIVEN THE NUMBERS 201 AND 202.

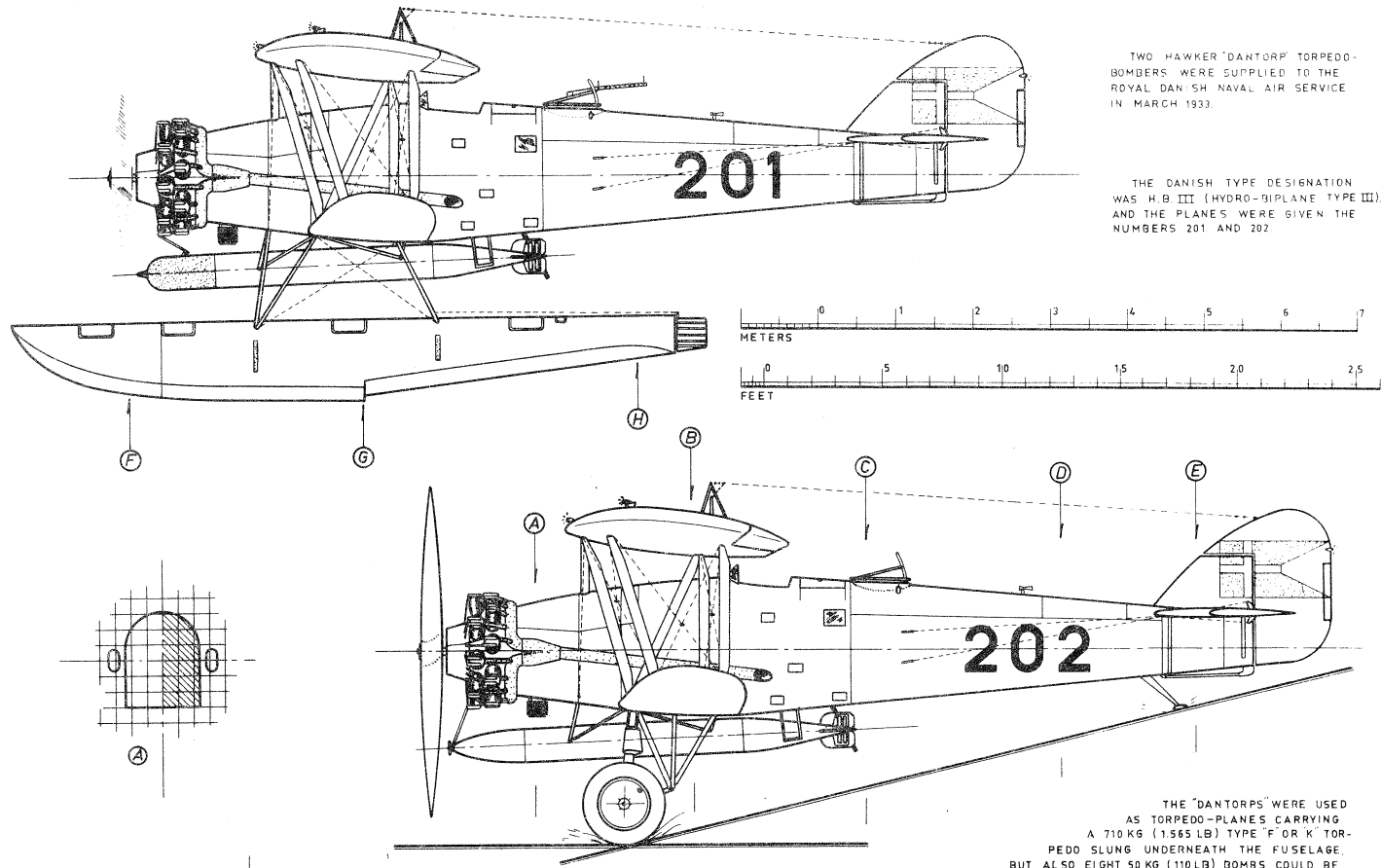

THE 'DANTORPS' WERE USED AS TORPEDO-PLANES CARRYING A 710 KG (1,565 LB) TYPE 'F' OR 'K' TORPEDO SLUNG UNDERNEATH THE FUSELAGE, BUT ALSO EIGHT 50 KG (110 LB) BOMBS COULD BE CARRIED UNDER THE WINGS IN VICKERS BOMB-RACKS.

