

PLANES WORTH MODELING

Work on the Ki.61-I began in Feb. 1940. By Dec. 1941 a prototype began flight tests & early in '42 quantity production was under way. The operational debut took place April 1943, at Wewak, New Guinea. Total production of all Ki.61-I's was 2,634 (Ki.61-Ia, Ib, Ic, & Id).

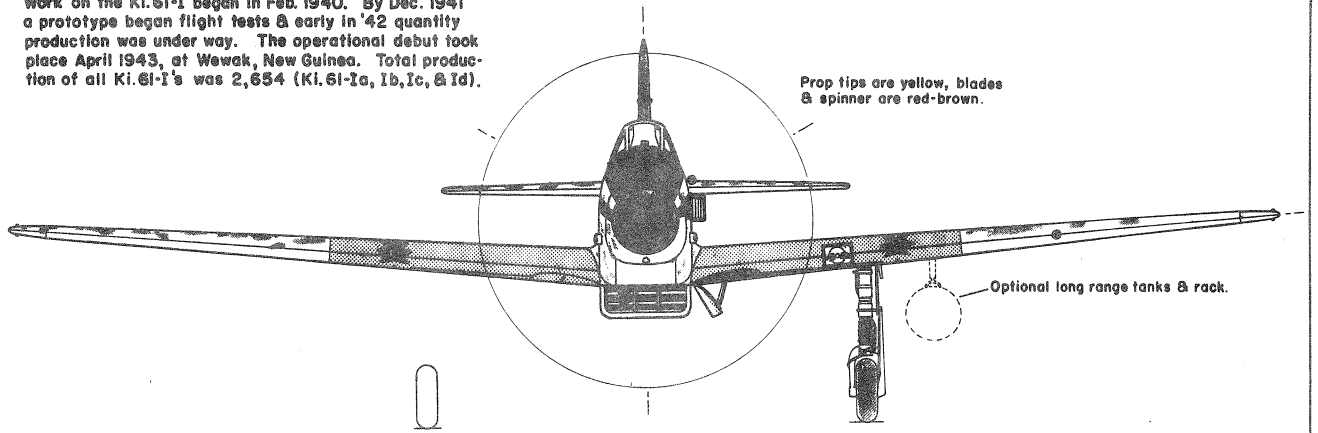

MAJOR TEMBICO KOBAYASHI'S TONY

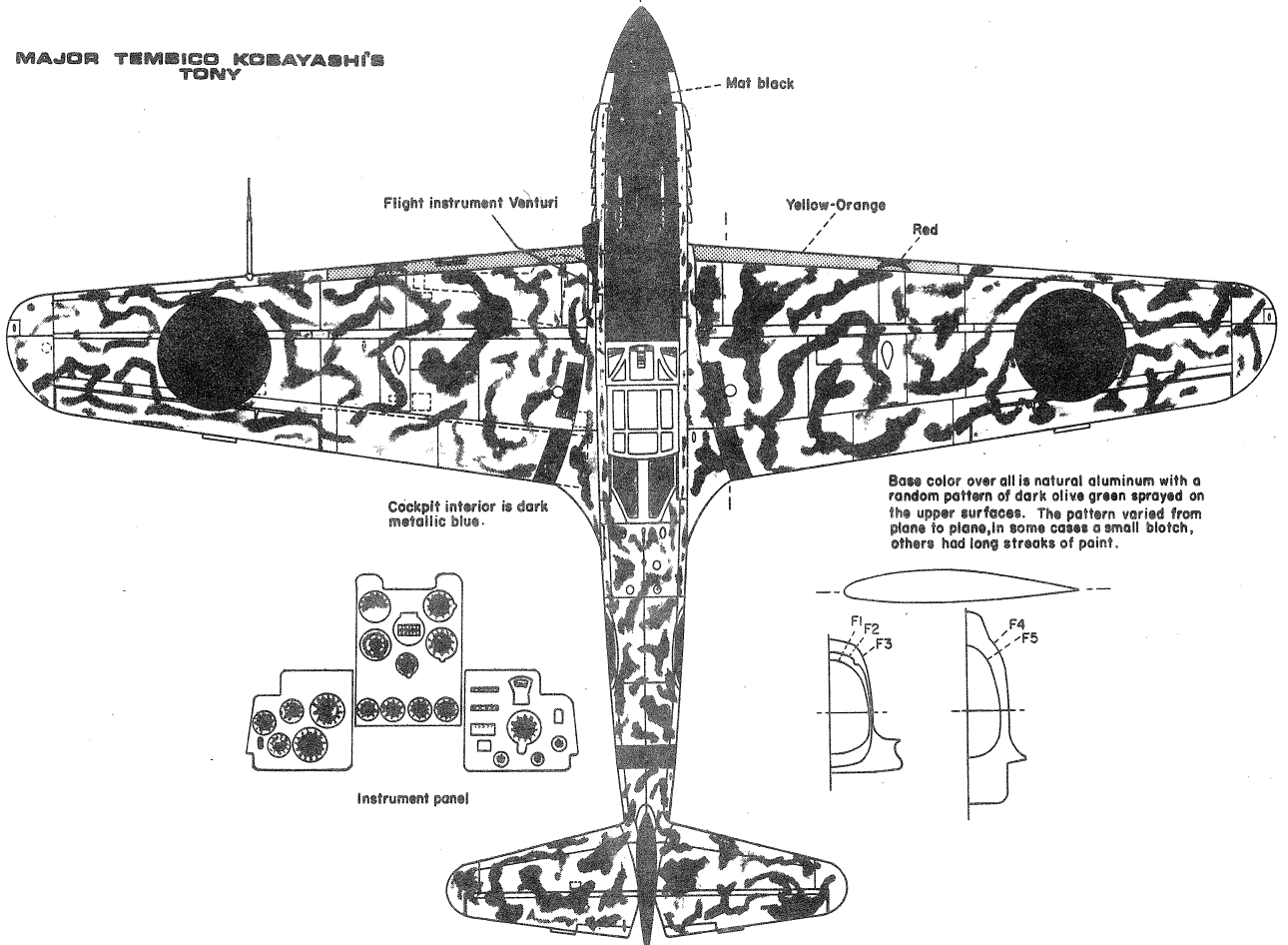

Base color over all is natural aluminum with a random pattern of dark olive green sprayed on the upper surfaces. The pattern varied from plane to plane, in some cases a small blotch, others had long streaks of paint.

Victory marks under cockpit were in the form of top view silhouettes of the type of plane accounted for. Photos indicate the types claimed were 2 single engine planes & 12 four engine planes. Color white.

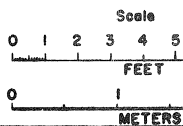
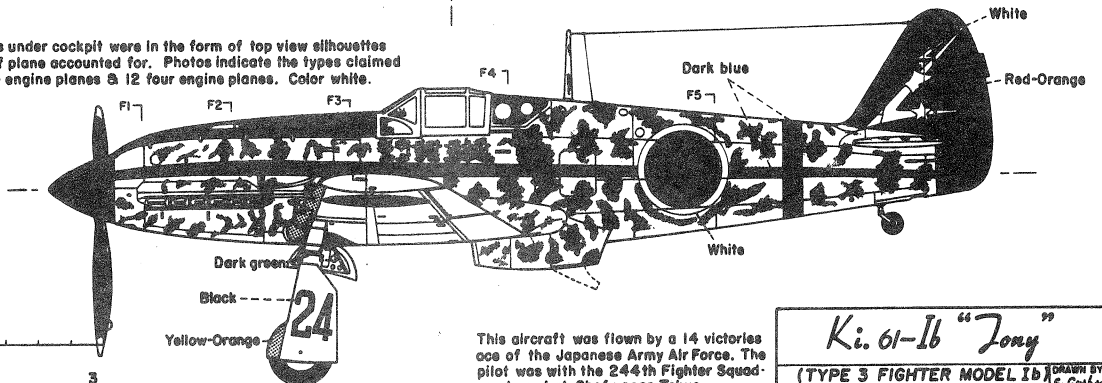

This aircraft was flown by a 14 victories ace of the Japanese Army Air Force. The pilot was with the 244th Fighter Squadron based at Chofu near Tokyo.

Ki. 61-1b "Tony"
 (TYPE 3 FIGHTER MODEL 1b) DRAWN BY
 KAWASAKI KOKUKI KOGYO Co. C. Graham