

KNIGHT TWISTER

Designed in 1928 by Vernon Payne, the Knight Twister was a pioneer in the field of small single-place aircraft. Although it wasn't a docile airplane, its sleek lines and fighter plane performance provided the inspiration for following generations of sport biplanes, and even a few modifications of the original, most notable being Marion Unruh's Pretty Prairie Special.

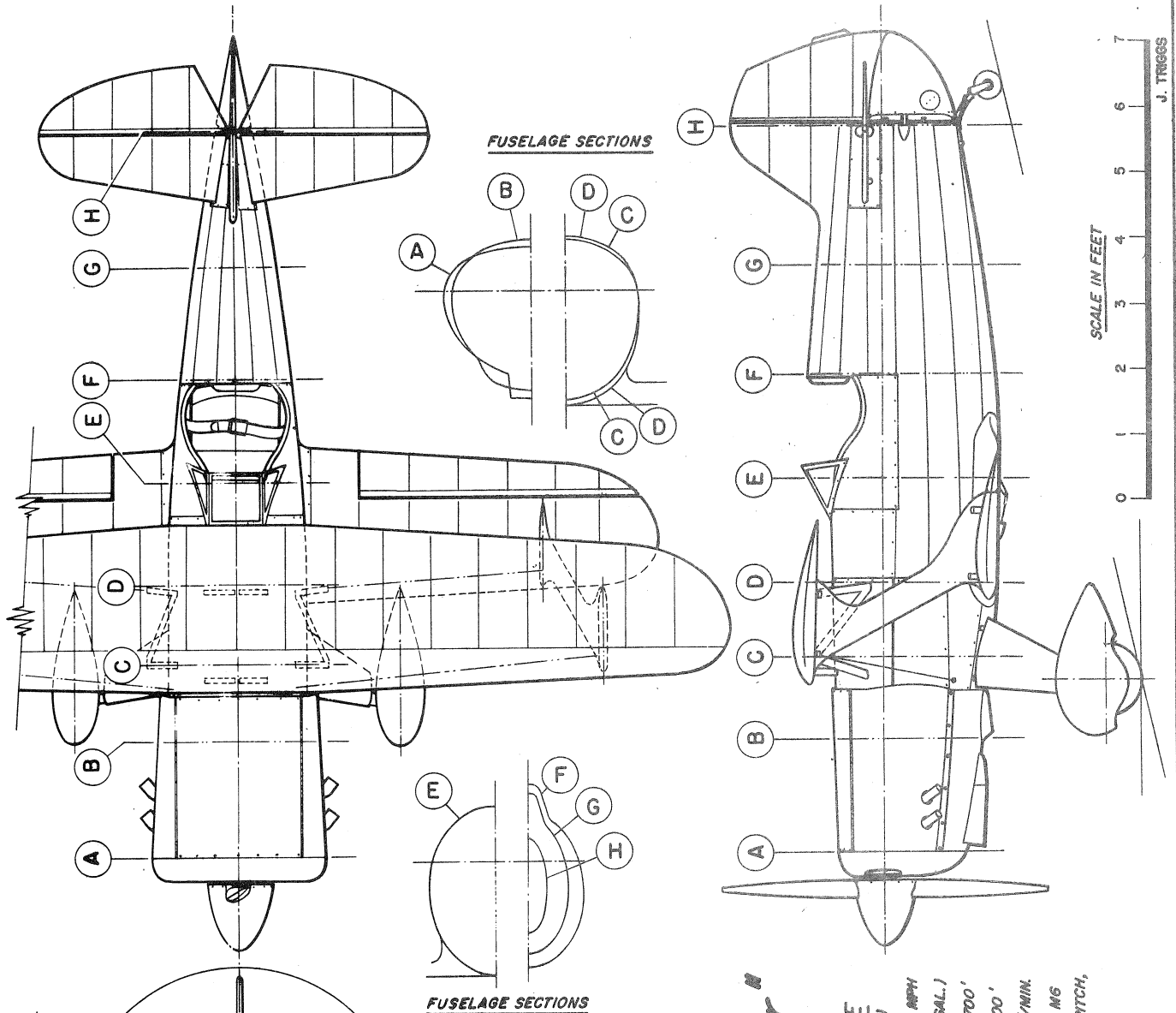

THE Knight "Twister"

DESIGNED BY VERNON W. PAYNE - 1928

SPECIFICATIONS AND PERFORMANCE

(TYPICAL MODERNIZED HOME-BUILT VERSION.)

| | | | |
|---------------------------------------|-----------|----------------|---------------------|
| TOP WING SPAN | 15' | STALLING SPEED | 85 MPH |
| LOWER WING SPAN | 13' | RANGE | ~ 300 MI. (22 GAL.) |
| LENGTH OVERALL | 14' | TAKEOFF RUN | 700' |
| WING AREA | 64 SQ.FT. | LANDING ROLL | 1800' |
| EMPTY WEIGHT | 540 LBS. | RATE OF CLIMB | 800'/MIN. |
| GROSS WEIGHT | 810 LBS. | AIRFOIL | - MG |
| TOP SPEED | 150 MPH. | PROPELLER | - FIXED PITCH, |
| CRUISING SPEED | 150 MPH. | | ALL-METAL |
| ENGINE - CONTINENTAL C-65-FJ, 85 H.P. | | | |