

GENERAL SPECIFICATION

WEIGHT EMPTY 1320 lbs.
 USEFUL LOAD 400 lbs. APPROX.
 GROSS WEIGHT 1720 lbs. (LAND PLANE VERSION)
 TOP SPEED 96 m.p.h.
 CRUISING SPEED 80 m.p.h.
 LANDING SPEED 45 m.p.h.
 GLIDE RATIO 12:1
 FUEL CAPACITY 50 gals.
 CLIMB TO 3500 FEET 10 min.
 RECORD CLIMB, 1915, - 5,200 feet in 10 min. 15 sec. (MARTIN TT No. 31)
 SERVICE CEILING, 2 PERSONS ABOARD, 9,500 feet
 WING AREA 379 sq. ft. (NOT INCL. AILERONS)
 POWER - CURTISS OX-2 90 hp

COLORING NOTES

ALUMINUM ENGINE COWLING AREA, COCKPIT COMBING - MEDIUM GRAY
 BALANCE OF AIRCRAFT - CLEAR DOPED FABRIC
 INTER-PLANE STRUTS - CLEAR VARNISHED ASH
 MAIN LANDING GEAR METAL STRUTS - BLACK

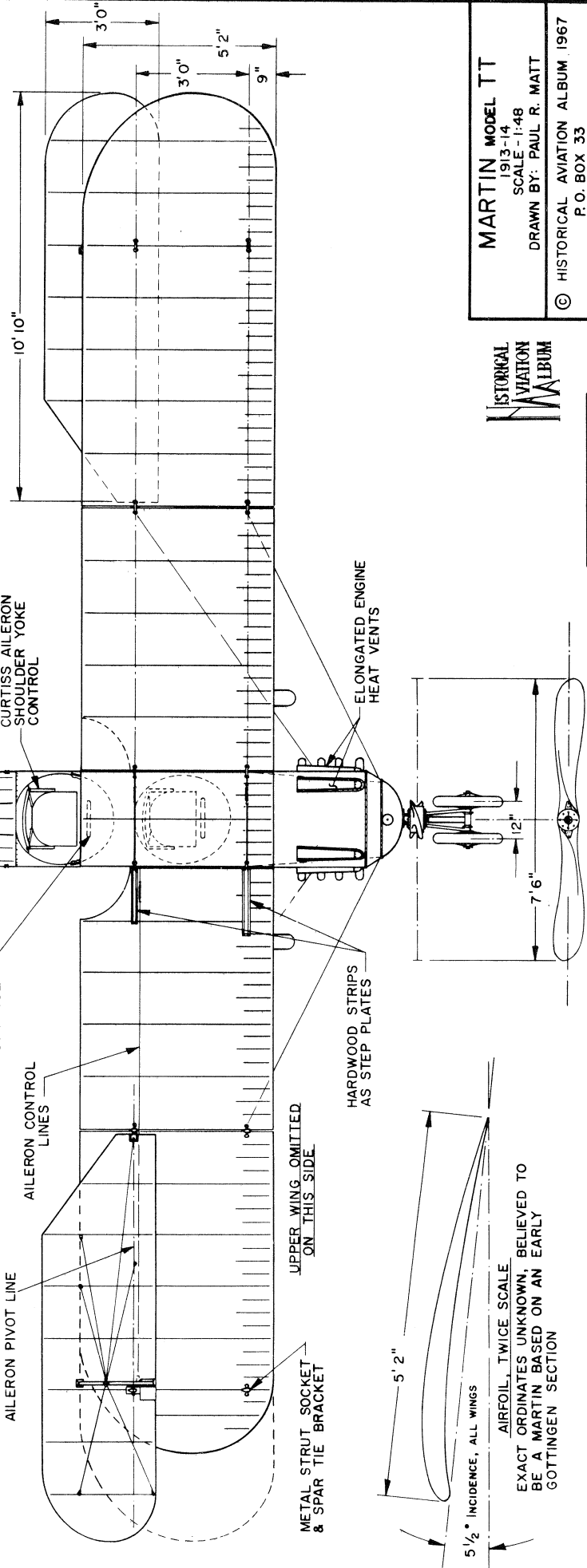
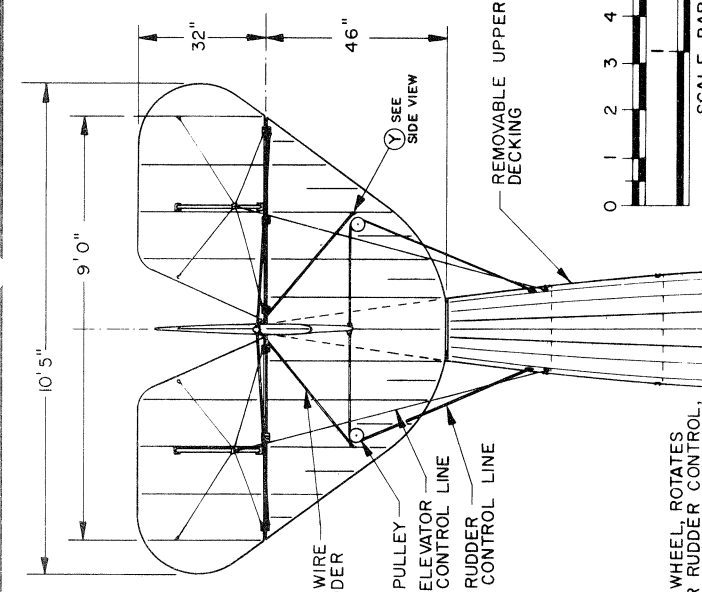
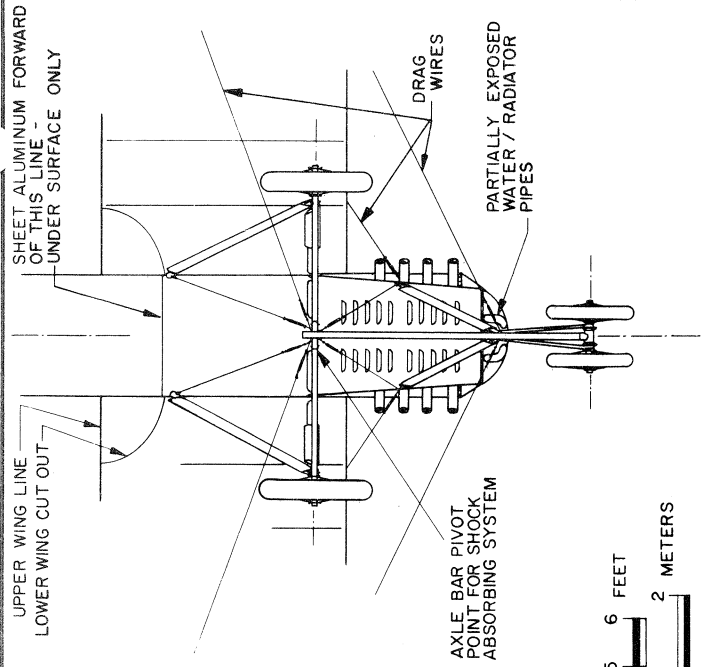

MARTIN MODEL TT
 1913-14
 SCALE - 1:48
 DRAWN BY: PAUL R. MATT
 © HISTORICAL AVIATION ALBUM 1967
 P O BOX 33
 TEMPLE CITY, CALIF. 91780

DRAWING No. 5-40-A

PLATE 1 of 2

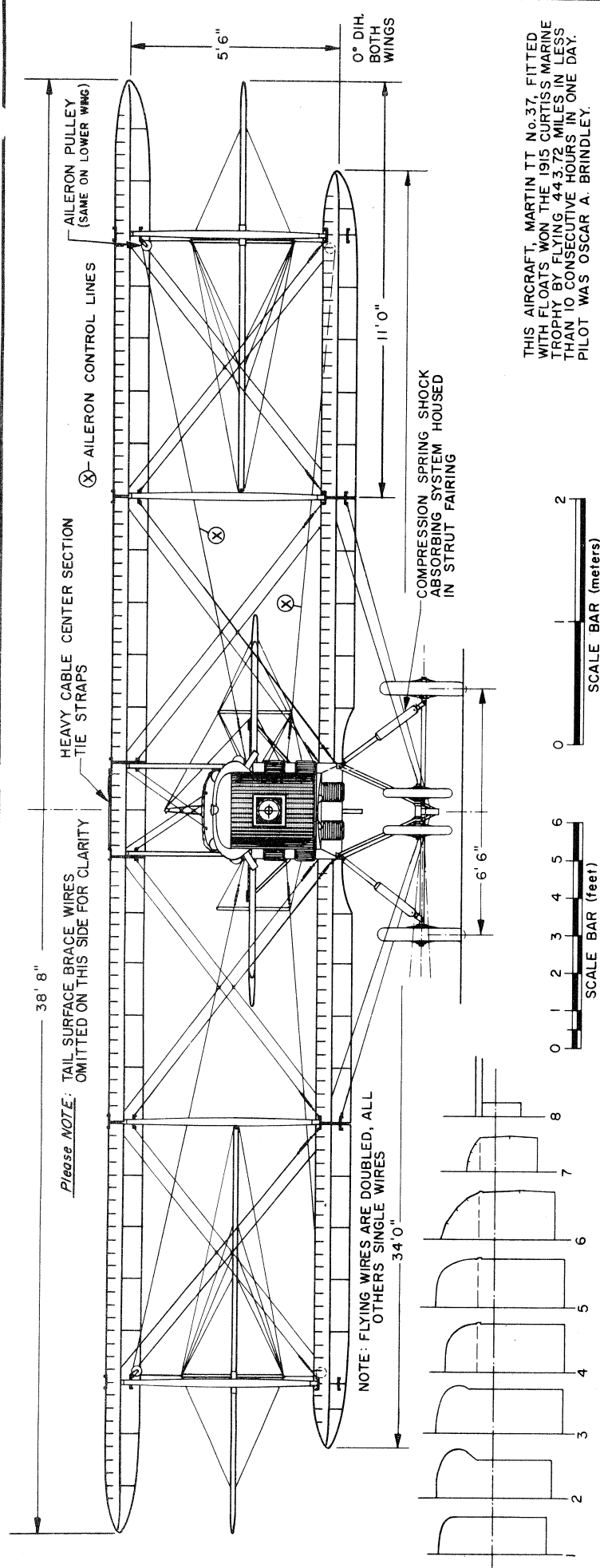

THIS AIRCRAFT, MARTIN TT No.37, FITTED WITH FLOATS WON THE 1915 CURTISS MARINE TROPHY BY FLYING 443.72 MILES IN LESS THAN 10 CONSECUTIVE HOURS IN ONE DAY. PILOT WAS OSCAR A. BRINDLEY.

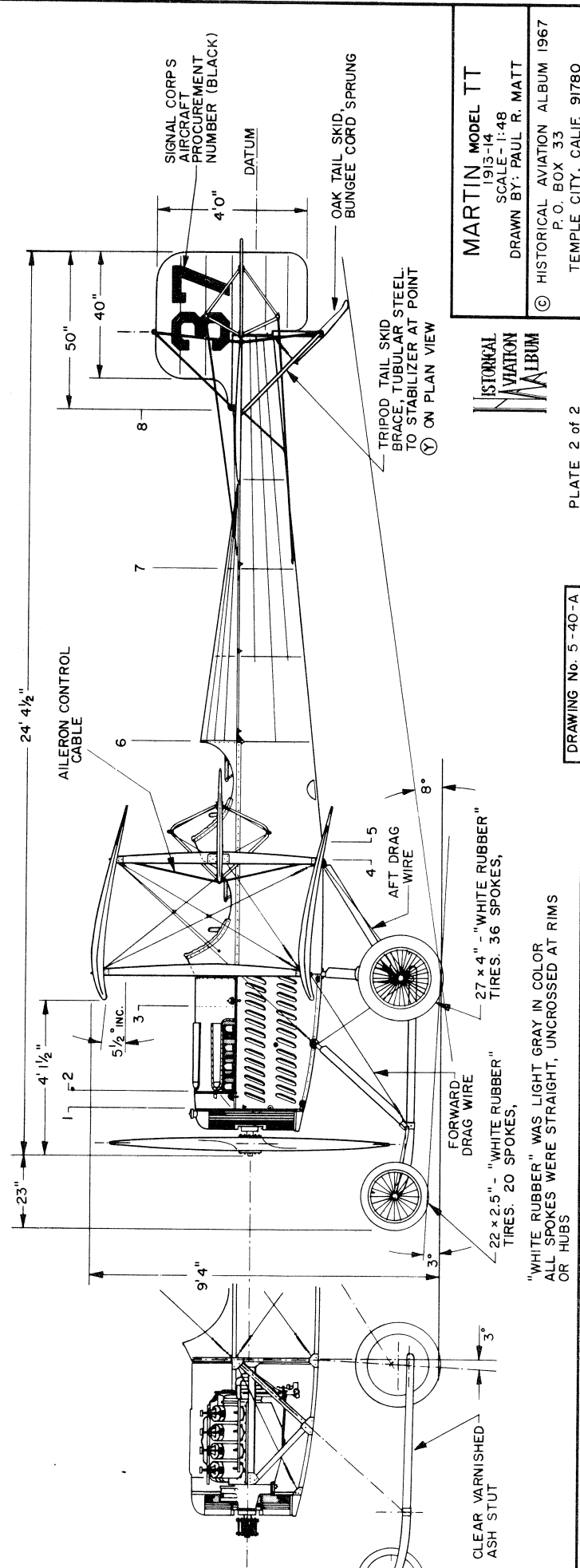

MARTIN MODEL TT
1913-14
SCALE - 1:48
DRAWN BY: PAUL R. MATT
P. O. BOX 33
TEMPLE CITY, CALIF. 91780

HISTORICAL AVIATION MUSEUM

DRAWING No. 5-40-A

PLATE 2 of 2