

U.S. NAME - ZIKE 52
 JAPANESE NAME - ZERO SEN TYPE 52 A6M5
 (TYPE 0) NAVY CAMOUFLAGE FIGHTER
 MANUFACTURED BY MITSUBISHI
 FIRST FLEW 4-21
 NO. MADE - 0-435 (NAVY - A6M5)
 0-436 (ARMY - A6M2)
 0-437 (ARMY - A6M3)
 0-438 (ARMY - A6M4)
 0-439 (ARMY - A6M5)
 0-440 (ARMY - A6M6)
 0-441 (ARMY - A6M7)
 0-442 (ARMY - A6M8)
 0-443 (ARMY - A6M9)
 0-444 (ARMY - A6M10)
 0-445 (ARMY - A6M11)
 0-446 (ARMY - A6M12)
 0-447 (ARMY - A6M13)
 0-448 (ARMY - A6M14)
 0-449 (ARMY - A6M15)
 0-450 (ARMY - A6M16)
 0-451 (ARMY - A6M17)
 0-452 (ARMY - A6M18)
 0-453 (ARMY - A6M19)
 0-454 (ARMY - A6M20)
 0-455 (ARMY - A6M21)
 0-456 (ARMY - A6M22)
 0-457 (ARMY - A6M23)
 0-458 (ARMY - A6M24)
 0-459 (ARMY - A6M25)
 0-460 (ARMY - A6M26)
 0-461 (ARMY - A6M27)
 0-462 (ARMY - A6M28)
 0-463 (ARMY - A6M29)
 0-464 (ARMY - A6M30)
 0-465 (ARMY - A6M31)
 0-466 (ARMY - A6M32)
 0-467 (ARMY - A6M33)
 0-468 (ARMY - A6M34)
 0-469 (ARMY - A6M35)
 0-470 (ARMY - A6M36)
 0-471 (ARMY - A6M37)
 0-472 (ARMY - A6M38)
 0-473 (ARMY - A6M39)
 0-474 (ARMY - A6M40)
 0-475 (ARMY - A6M41)
 0-476 (ARMY - A6M42)
 0-477 (ARMY - A6M43)
 0-478 (ARMY - A6M44)
 0-479 (ARMY - A6M45)
 0-480 (ARMY - A6M46)
 0-481 (ARMY - A6M47)
 0-482 (ARMY - A6M48)
 0-483 (ARMY - A6M49)
 0-484 (ARMY - A6M50)
 0-485 (ARMY - A6M51)
 0-486 (ARMY - A6M52)
 0-487 (ARMY - A6M53)
 0-488 (ARMY - A6M54)
 0-489 (ARMY - A6M55)
 0-490 (ARMY - A6M56)
 0-491 (ARMY - A6M57)
 0-492 (ARMY - A6M58)
 0-493 (ARMY - A6M59)
 0-494 (ARMY - A6M60)
 0-495 (ARMY - A6M61)
 0-496 (ARMY - A6M62)
 0-497 (ARMY - A6M63)
 0-498 (ARMY - A6M64)
 0-499 (ARMY - A6M65)
 0-500 (ARMY - A6M66)
 0-501 (ARMY - A6M67)
 0-502 (ARMY - A6M68)
 0-503 (ARMY - A6M69)
 0-504 (ARMY - A6M70)
 0-505 (ARMY - A6M71)
 0-506 (ARMY - A6M72)
 0-507 (ARMY - A6M73)
 0-508 (ARMY - A6M74)
 0-509 (ARMY - A6M75)
 0-510 (ARMY - A6M76)
 0-511 (ARMY - A6M77)
 0-512 (ARMY - A6M78)
 0-513 (ARMY - A6M79)
 0-514 (ARMY - A6M80)
 0-515 (ARMY - A6M81)
 0-516 (ARMY - A6M82)
 0-517 (ARMY - A6M83)
 0-518 (ARMY - A6M84)
 0-519 (ARMY - A6M85)
 0-520 (ARMY - A6M86)
 0-521 (ARMY - A6M87)
 0-522 (ARMY - A6M88)
 0-523 (ARMY - A6M89)
 0-524 (ARMY - A6M90)
 0-525 (ARMY - A6M91)
 0-526 (ARMY - A6M92)
 0-527 (ARMY - A6M93)
 0-528 (ARMY - A6M94)
 0-529 (ARMY - A6M95)
 0-530 (ARMY - A6M96)
 0-531 (ARMY - A6M97)
 0-532 (ARMY - A6M98)
 0-533 (ARMY - A6M99)
 0-534 (ARMY - A6M100)

SPECIFICATIONS
 SPAN - 36' 1" LENGTH - 29' 3"
 HEIGHT - 16' 6" WEIGHT - 5,860 LBS.
 AIR-COOL RADIAL (MITSUBISHI)
 1,000 HP (MITSUBISHI)
 MAXIMUM SPEED (M.P.H.) 375 @ 20,000'
 CLIMB RATE (M.P.H.) 10,000'
 RANGE (M.P.H.) 1,500
 CREW - 1

THE JAPANESE ZEKE

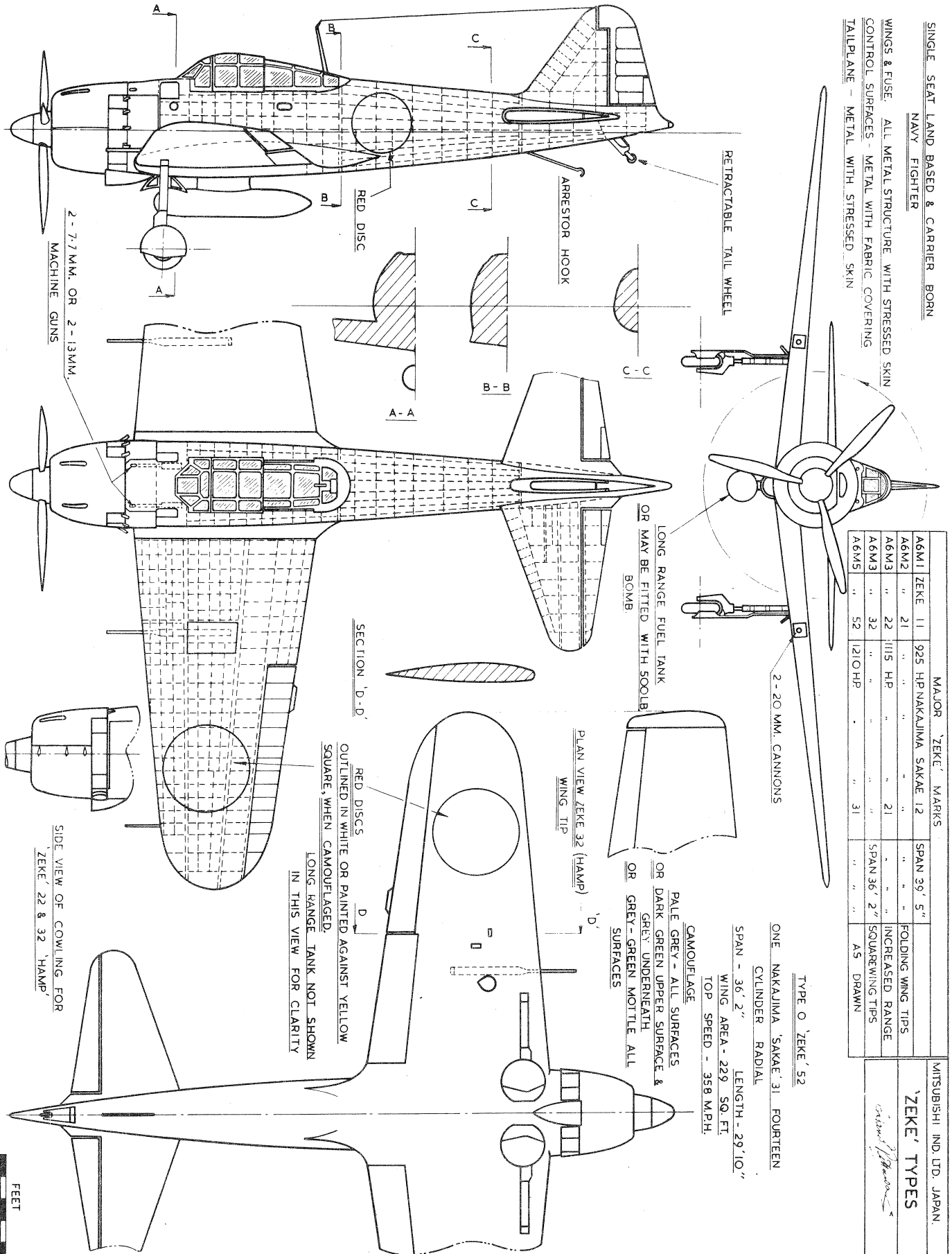

SINGLE SEAT LAND BASED & CARRIER BORN
NAVY FIGHTER

WINGS & FUSE. ALL METAL STRUCTURE WITH STRESSED SKIN
CONTROL SURFACES - METAL WITH FABRIC COVERING
TAILPLANE - METAL WITH STRESSED SKIN

	MAJOR 'ZEKE' MARKS				MITSUBISHI IND. LTD. JAPAN
A6M1 ZEKE 11	925 HP NAKAJIMA SAKAE 12	SPAN 39' 5"	FOLDING WING TIPS		'ZEKE' TYPES <i>Zeke</i>
A6M2	21	"	"		
A6M3	22 1115 HP	21	INCREASED RANGE		
A6M3	32	"	SQUARE WING TIPS		
A6M5	52 1210 HP	31	AS DRAWN		

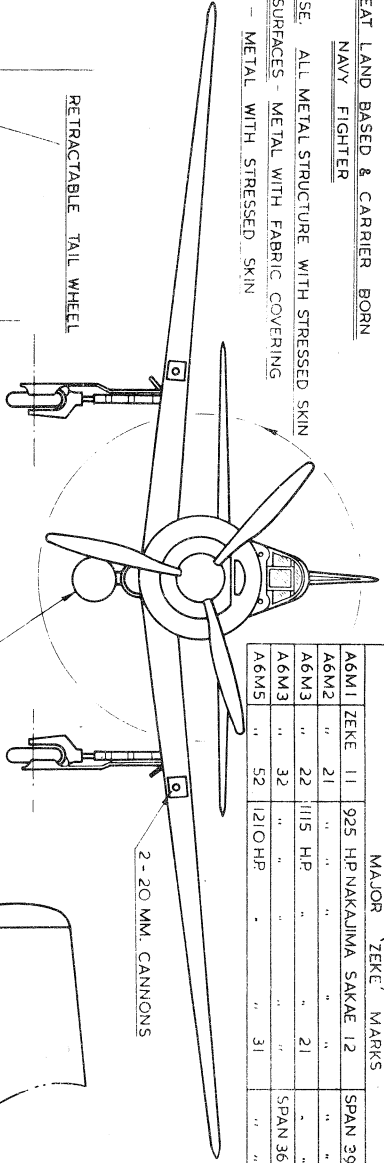

LONG RANGE FUEL TANK
OR MAY BE FITTED WITH SOULB BOMB

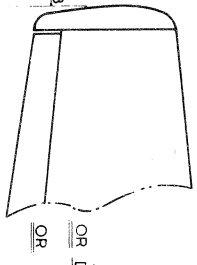

PALE GREY - ALL SURFACES
OR DARK GREEN UPPER SURFACE & GREY UNDERNEATH
OR GREY-GREEN MOTTLE ALL SURFACES

TYPE O 'ZEKE' 52
ONE NAKAJIMA 'SAKAE' 31 FOURTEEN
CYLINDER RADIAL
SPAN - 36' 2" LENGTH - 29' 10"
WING AREA - 229 SQ. FT.
TOP SPEED - 358 M.P.H.



PLAN VIEW ZEKE 32 (HAMP)
WING TIP

RED DISCS
OUTLINED IN WHITE OR PAINTED AGAINST YELLOW
SQUARE, WHEN CAMOUFLAGED.
LONG RANGE TANK NOT SHOWN
IN THIS VIEW FOR CLARITY

2 - 7.7 MM. OR 2 - 13MM.
MACHINE GUNS

SIDE VIEW OF COWLING FOR
'ZEKE' 22 & 32 'HAMP'



PLANES WORTH MODELING

MODEL	ENGINE	H.P.	SPEED	AT ALTITUDE OF
A6M2	SAKAE 12 (Ha. 35/12)	925	317	16,400 FT.
A6M3	SAKAE 21 (Ha. 35/21)	1,130	341	20,500
A6M5	" "	"	358	22,000
A6M5c	" "	"	346	19,600

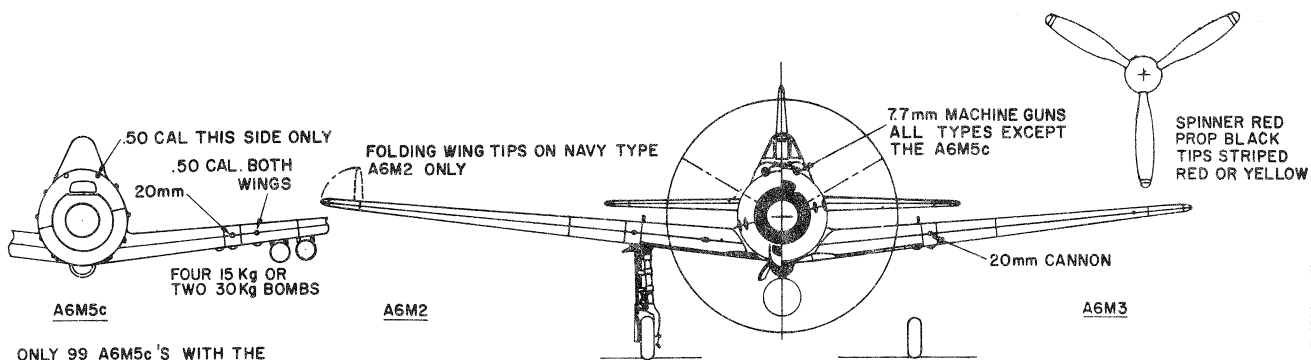

ONLY 99 A6M5c's WITH THE .50 CAL. GUNS WERE BUILT SINCE THE ADDITIONAL WEIGHT AFFECTED THE PERFORMANCE SO BADLY.

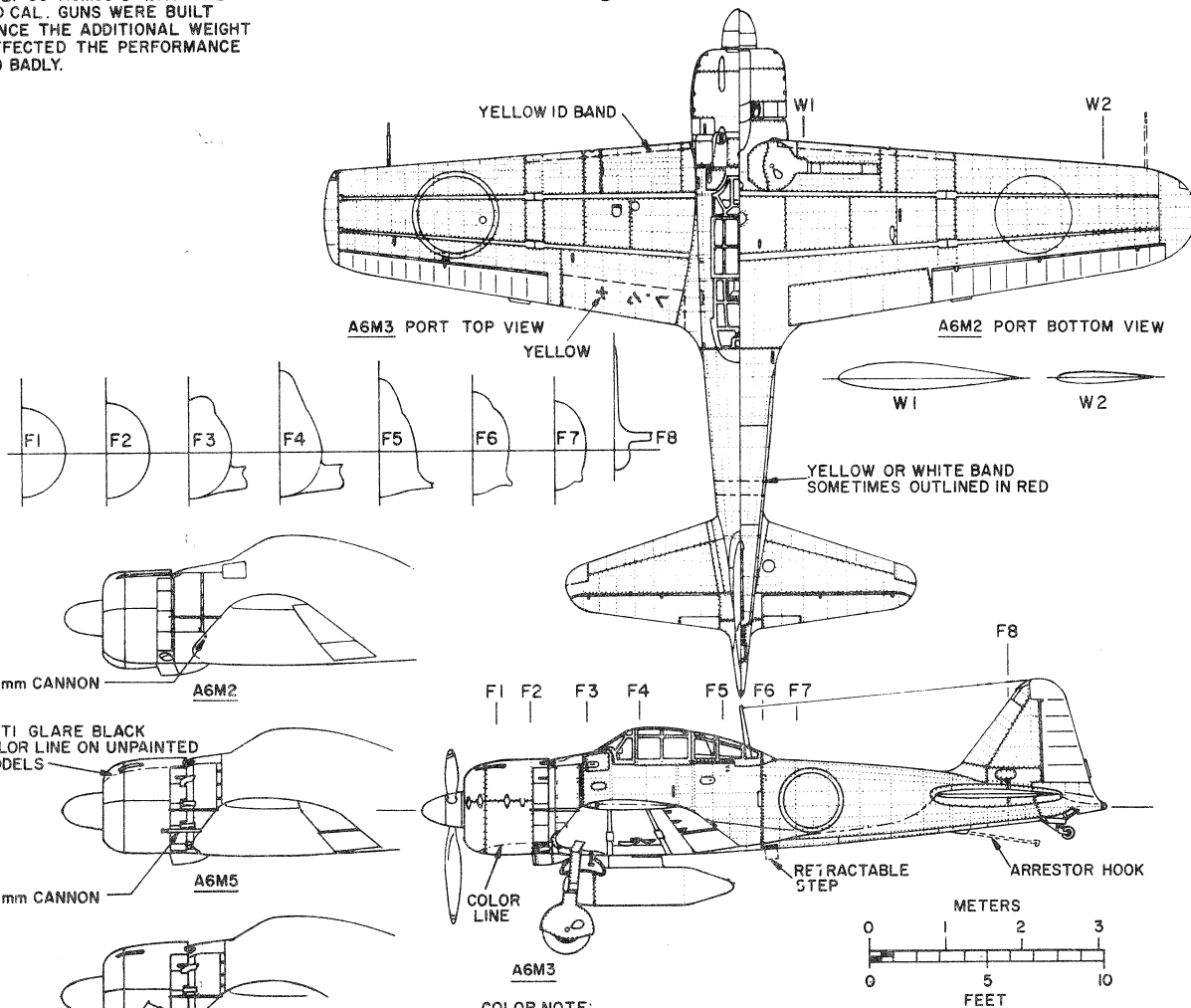

COLOR NOTE:

MOST WIDELY USED SCHEME, A BROWNISH OLIVE GREEN ON UPPER SURFACE WITH A WARM LIGHT GREY UNDER-SIDE.

Mitsubishi Type Zero or "Zeke"

A6M2, A6M3 "HAMP", A6M5, and A6M5c

SCALE 1/8" = 1'

Drawn by C. Graham

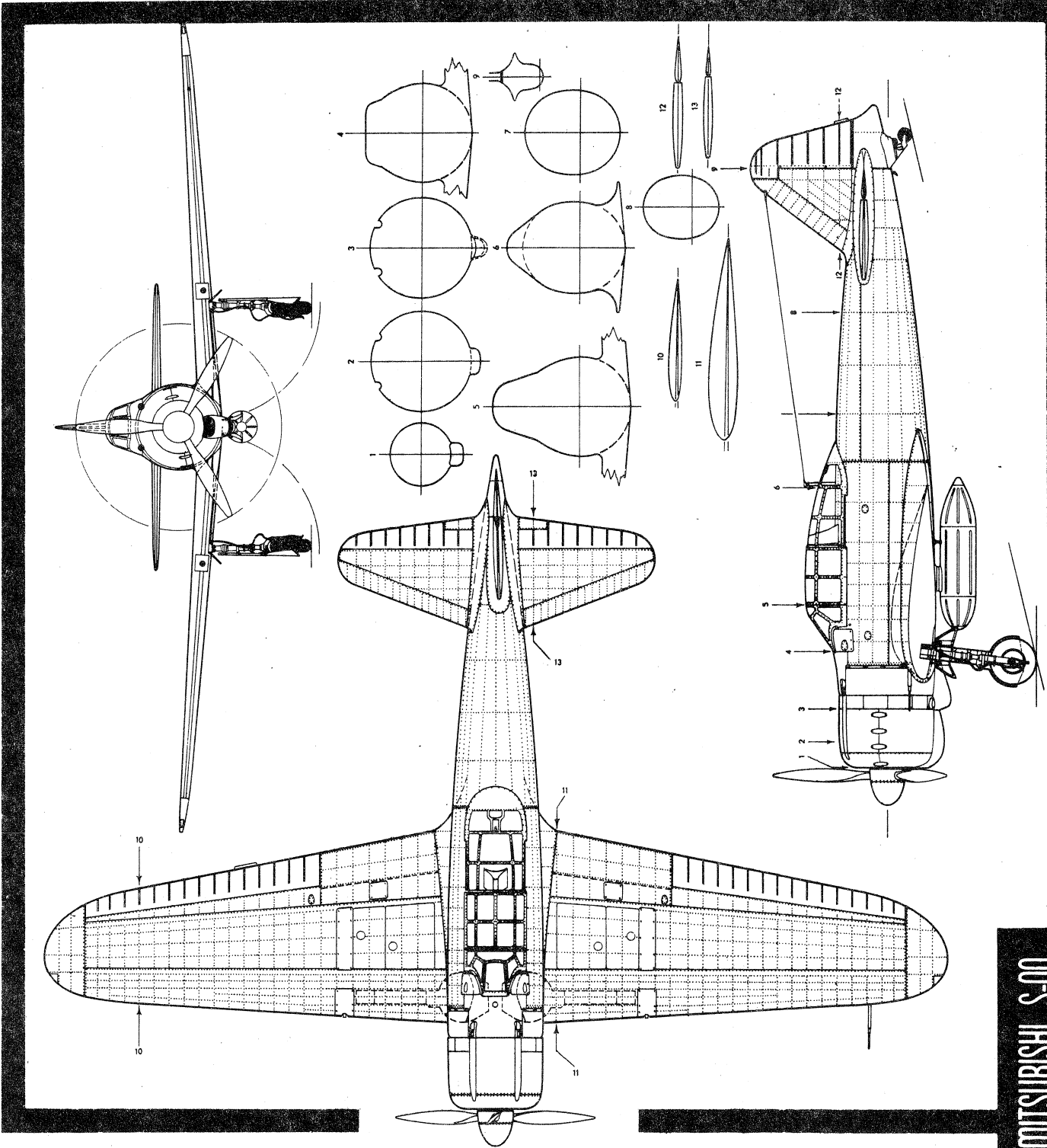

MITSUBISHI S-00