

HG

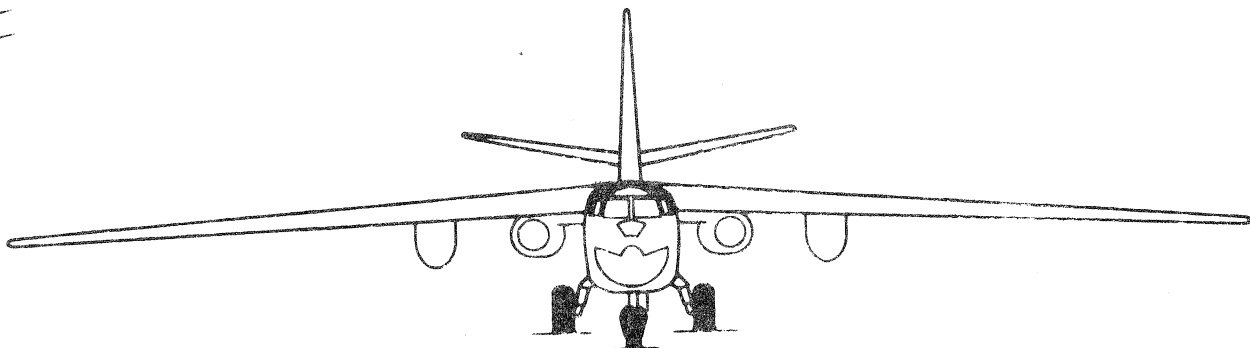

X-21A
USAF - NORTHROP
LAMINAR FLOW AIRCRAFT

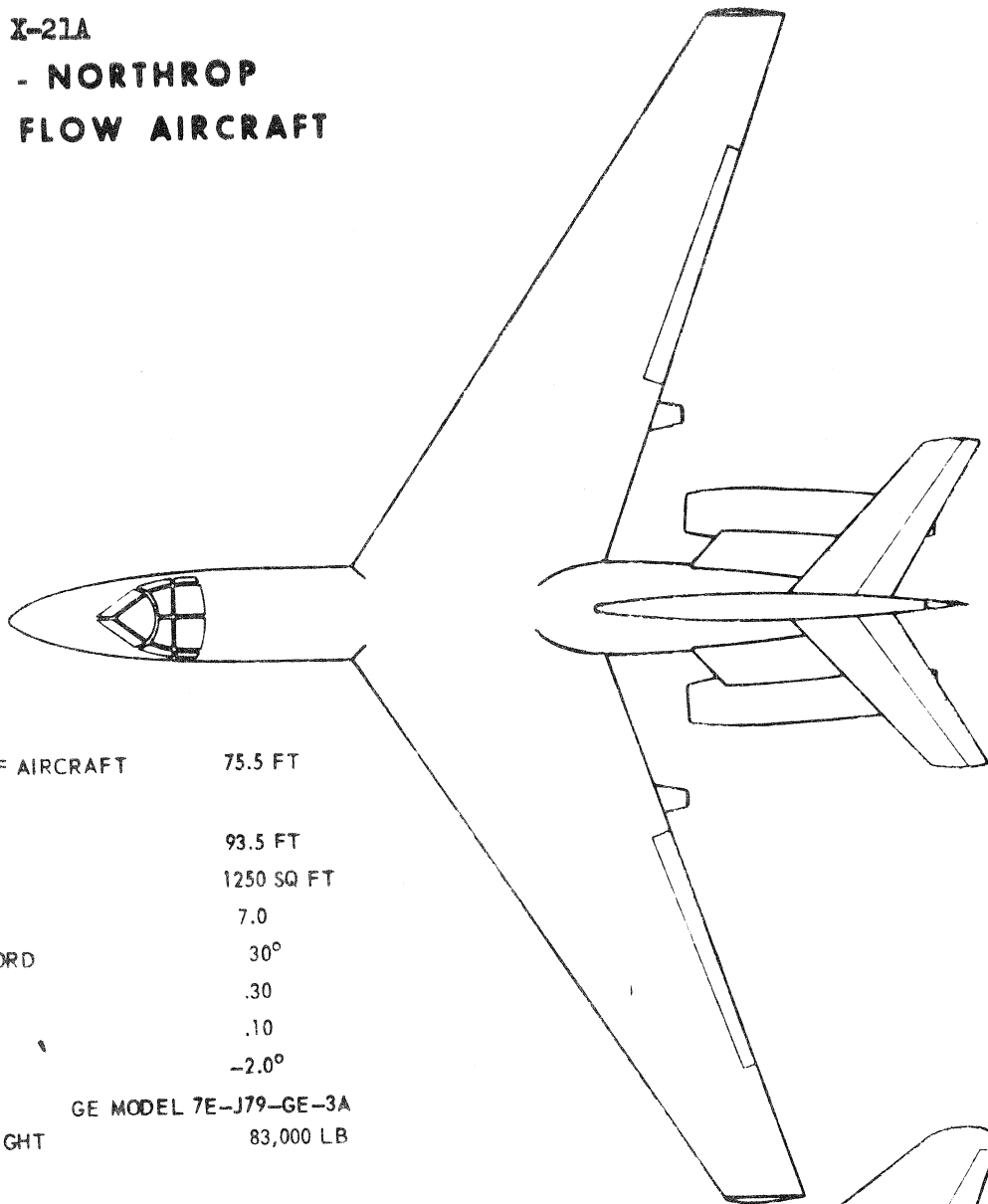

OVERALL LENGTH OF AIRCRAFT	75.5 FT
WING	
SPAN	93.5 FT
AREA	1250 SQ FT
ASPECT RATIO	7.0
SWEEP AT 1/4 CHORD	30°
TAPER RATIO	.30
THICKNESS RATIO	.10
DIHEDRAL	-2.0°
ENGINES	GE MODEL 7E-J79-GE-3A
GROSS TAKEOFF WEIGHT	83,000 LB

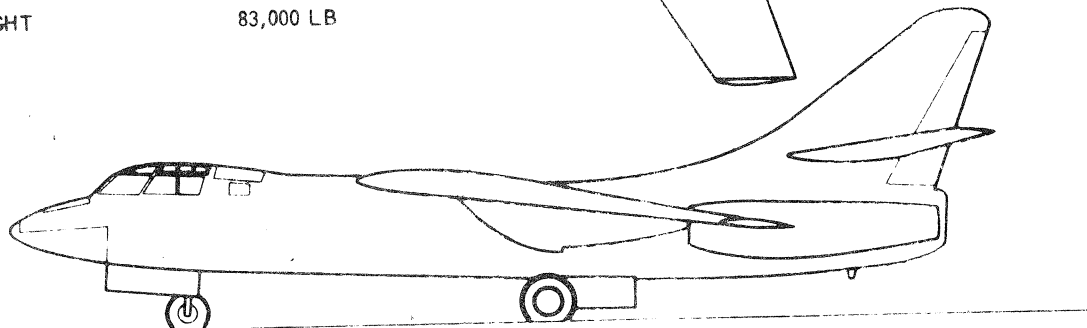

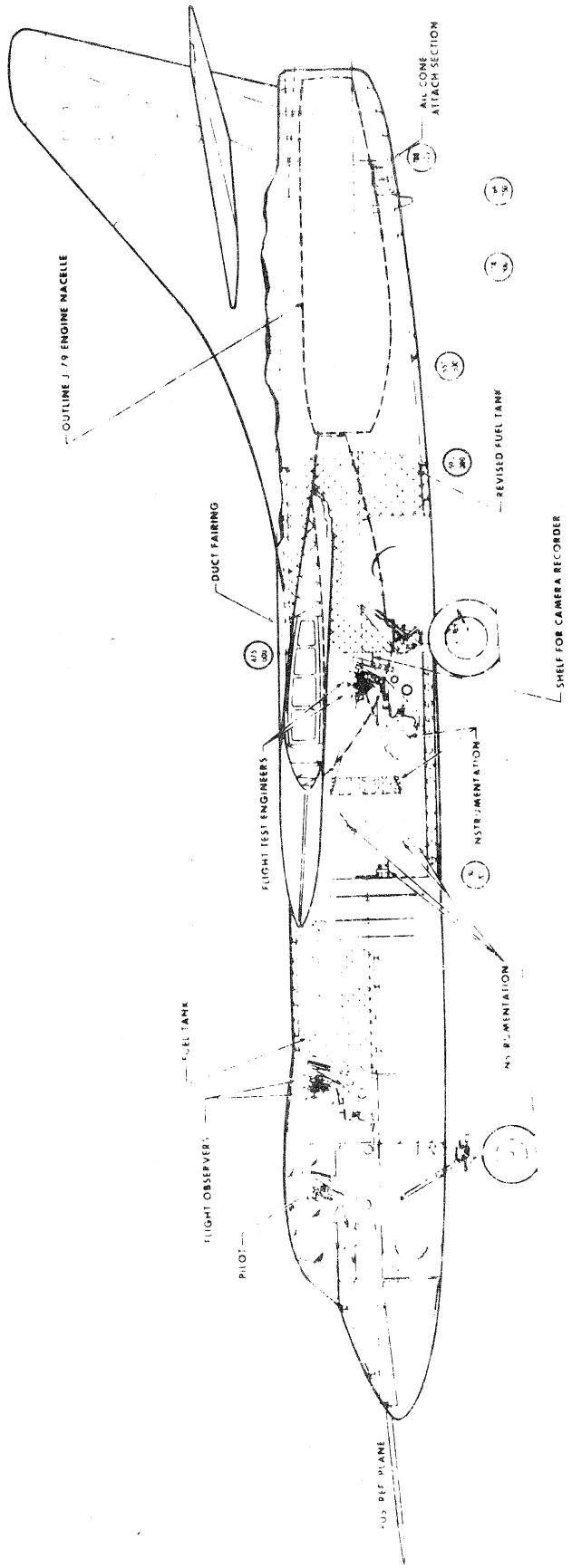

X-21A
 USAF NORTHROP LAMINAR FLOW AIRCRAFT
 CUTAWAY VIEW