

PERFORMANCE: MAX SPEED, 201 MPH AT SEA LEVEL • INITIAL CLIMB RATE, 2,200 FT./MIN. • RANGE, 648 MILES • CEILING, 25,000 FT.

WEIGHTS: 3,350 LBS (EMPTY)
AND 4,400 LBS (LOADED)

POWERED BY ONE
550-H.P. ALVIS
LEONIDES 126 JET

SPAN: 35 FT. 2 IN.
LENGTH: 28 FT. 8 IN.
WING AREA: 214 SQ. FT.

—BILL DEAN

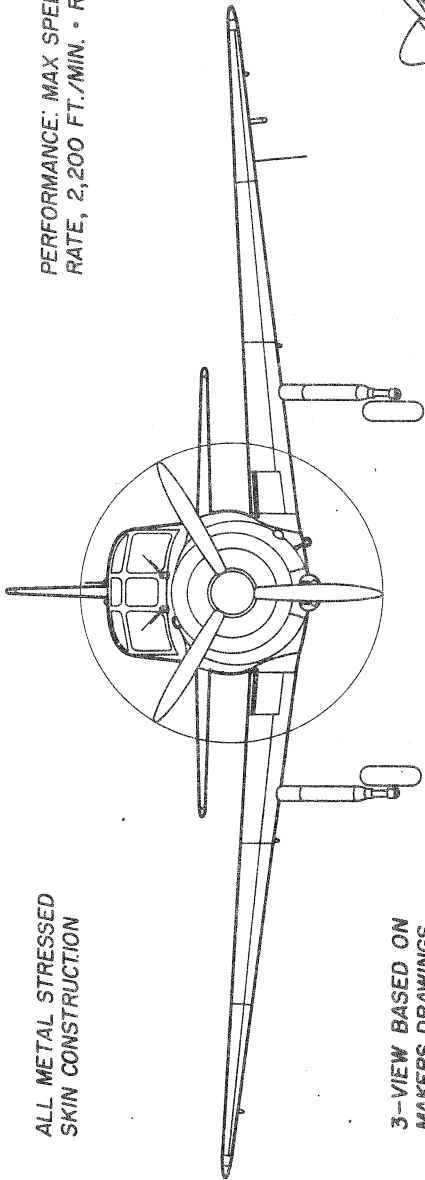

3-VIEW BASED ON
MAKERS DRAWINGS
AND PHOTOGRAPHS

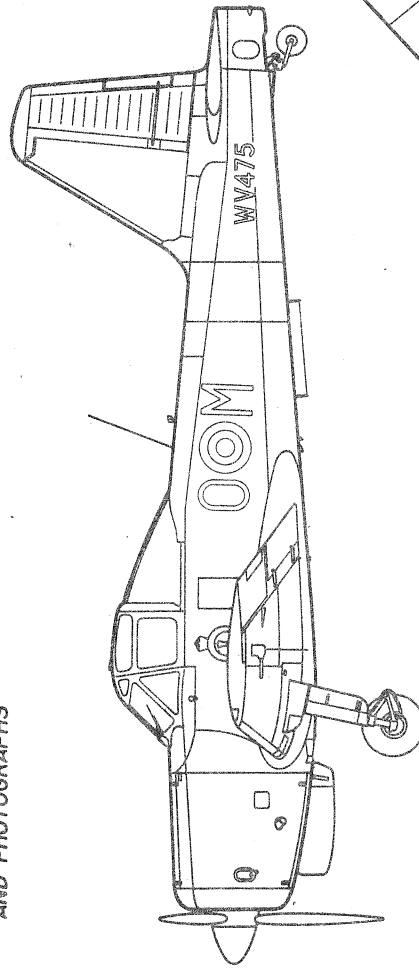

PERCIVAL PROVOST T.1 TRAINER

FIRST FLOWN IN 1950, THE BRITISH PROVOST IS LIKELY TO BE THE LAST PISTON-ENGINE TRAINER TO SEE SERVICE WITH THE ROYAL AIR FORCE. THE FIRST TWO PROTOTYPES WERE POWERED BY ARMSTRONG SIDDELEY CHEETAH 18 ENGINES, BUT ALVIS LEONIDES WERE SUBSTITUTED IN THE PRODUCTION AIRCRAFT. IN 1954, A JET VERSION OF THE PROVOST WAS AIRBORNE AND THESE AIRCRAFT ARE NOW ALSO IN USE WITH THE RAF. THE JET PROVOST FEATURES A NEW FUSELAGE, RETRACTING TRICYCLE LANDING GEAR AND SLIGHTLY MODIFIED PROVOST WINGS AND TAIL UNIT.

