

PIPER

Comanche

PA 24

MANUFACTURED BY

Piper Aircraft Corporation

LOCK HAVEN, PENNSYLVANIA

SPECIFICATIONS

PERFORMANCE

| | | |
|-----------------------------------|---|-------------------|
| WING SPAN | - | 36 FT. |
| WING AREA | - | 178 SQ. FT. |
| LENGTH | - | 24.9 FT. |
| HEIGHT | - | 7.3 FT. |
| POWER LOADING | - | 11.2 LBS./H.P. |
| WING LOADING | - | 15.7 LBS./SQ. FT. |
| GROSS WEIGHT | - | 2900 LBS. |
| EMPTY WEIGHT | - | 1630 LBS. |
| USEFUL LOAD | - | 1270 LBS. |
| BAGGAGE CAPACITY | - | 200 LBS. |
| FUEL CAPACITY (STANDARD) | - | 60 GALS. |
| FUEL CAPACITY (WITH RESERVE) 90 " | - | |
| ENGINE - LYCOMING O-540-A1A5, | | |
| 250 H.P. (2575 R.P.M.) | | |
| OR - LYCOMING O-360-A, 180 H.P. | | |

| | | |
|-----------------------------------|---|---------------|
| TOP SPEED | - | 190 M.P.H. |
| CRUISING SPEED (75%) | - | 181 M.P.H. |
| STALL SPEED (FLAPS DOWN) | - | 65 M.P.H. |
| TAKE OFF RUN | - | 1000 FT. |
| LANDING ROLL (FLAPS DOWN) | - | 650 FT. |
| RATE OF CLIMB | - | 1350 FT./MIN. |
| SERVICE CEILING | - | 20,000 FT. |
| ABSOLUTE CEILING | - | 22,000 FT. |
| CRUISING RANGE (STANDARD, OPTIMUM | | |
| (CRUISE) 7.5 HR., 1100 MI. | | |
| FUEL CONSUMPTION - (75% POWER) | | |
| | - | 14 GAL./HR. |

- FIGURES SHOWN ARE FOR 250 MODEL.

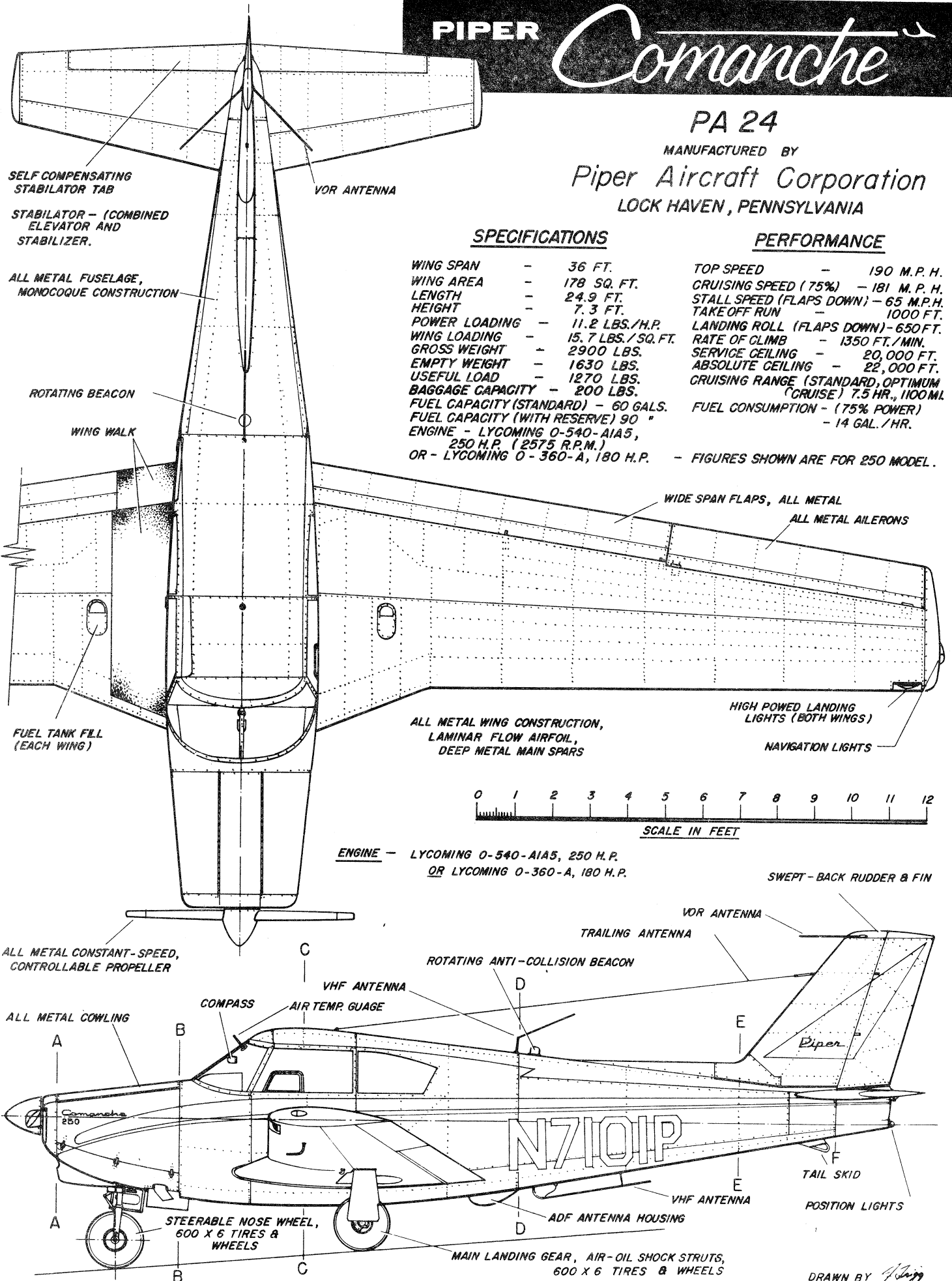

ENGINE - LYCOMING O-540-A1A5, 250 H.P.
OR LYCOMING O-360-A, 180 H.P.

SWEPT-BACK RUDDER & FIN

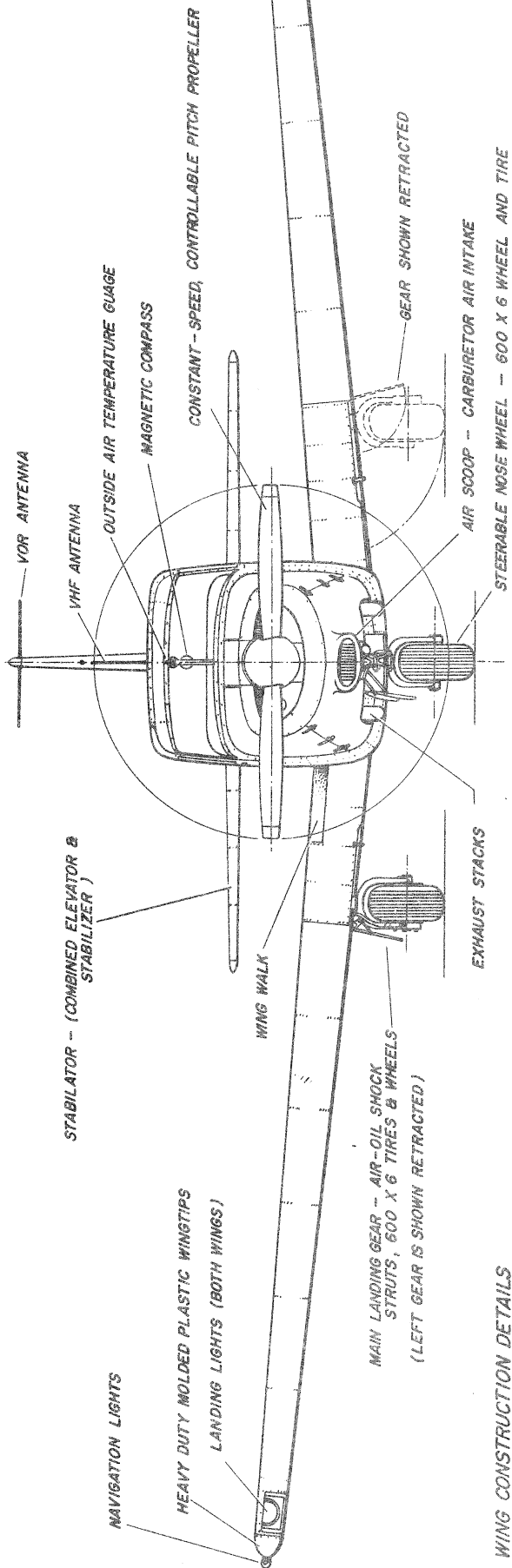

WING CONSTRUCTION DETAILS

SECTION AA -- ROOT RIB
LAMINAR FLOW AIRFOIL

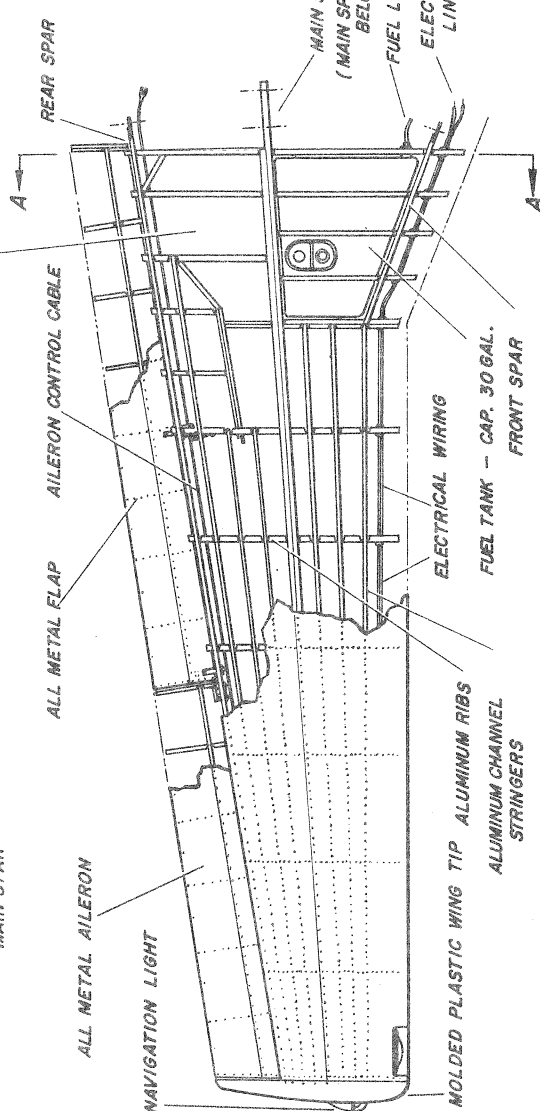
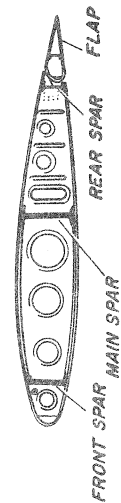

TAIL SECTION CONSTRUCTION DETAILS

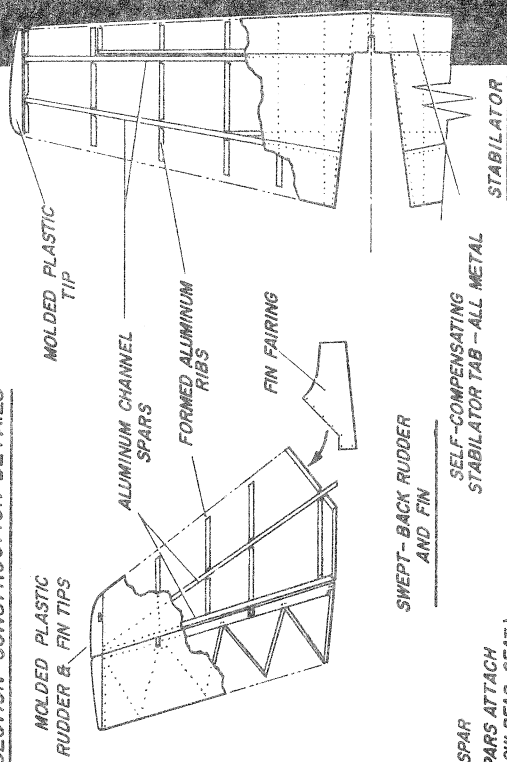

**PIPER PA 24
COMANCHE**

MANUFACTURED BY
 PIPER AIRCRAFT CORPORATION
 LOCK HAVEN, PENN.

DRAWN BY
A. Seipp

