

1940  
**PORTERFIELD**  
CP-65 "COLLEGIATE"

SPAN ..... 34' 9"  
LENGTH ..... 22' 8"  
HEIGHT ..... 7' 3"  
ENGINE ..... CONTINENTAL A-65-B  
65 H.P. at 2300 R.P.M.  
PROPELLER .....  
SENSENICH 72" X 44"

**PERFORMANCE:**

HIGH SPEED ..... 106 M.P.H.  
CRUISE SPEED ..... 94 M.P.H.  
POWER OFF STALL 40 M.P.H.  
POWER ON STALL 38 M.P.H.  
CLIMB RATE ..... 800 F.P.M.  
SERVICE CEILING 16,000 FT.  
RANGE ..... 300 MILES

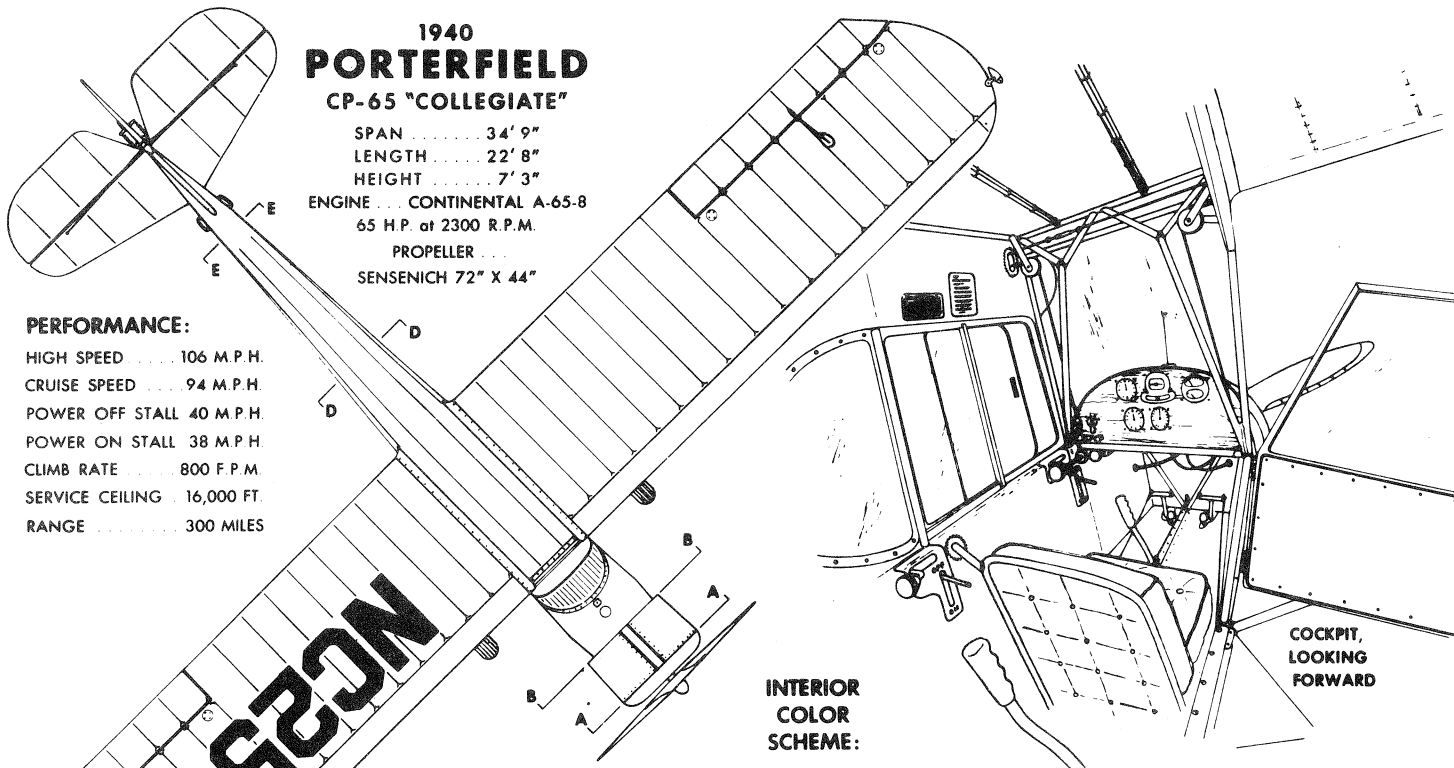

**INTERIOR  
COLOR  
SCHEME:**

All interior exposed steel tubes are gloss black enamel including the control members. The fabric covered interior side panels are dark red to match the exterior of the fuselage. The seat cushions and the door paneling are black leather. The instrument panel and the floor boards are natural wood color but the instrument panel is made of sheet metal. The instrument faces are white with black lettering. The throttle quadrants and all knobs are chrome plated. The exposed stringers on the ceiling are varnished wood.

**EXTERIOR COLOR SCHEME:**

The fuselage, vertical fin, rudder and wing struts are dark red. The wings, horizontal fin, elevator, hub caps and fuselage and speed fairing trim are silver. The numbers on the wings are black. On the tail they are silver.

COCKPIT,  
LOOKING  
FORWARD

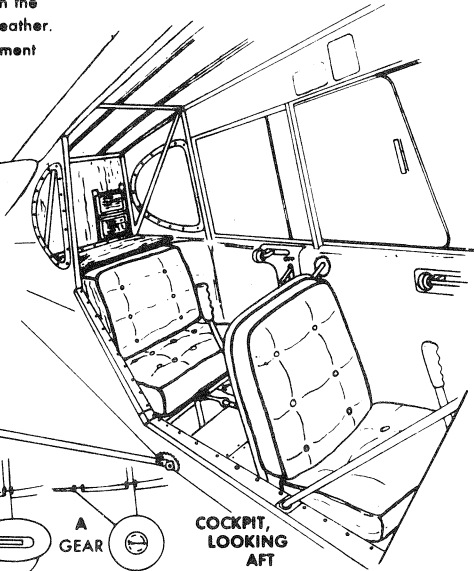

COCKPIT,  
LOOKING  
AFT

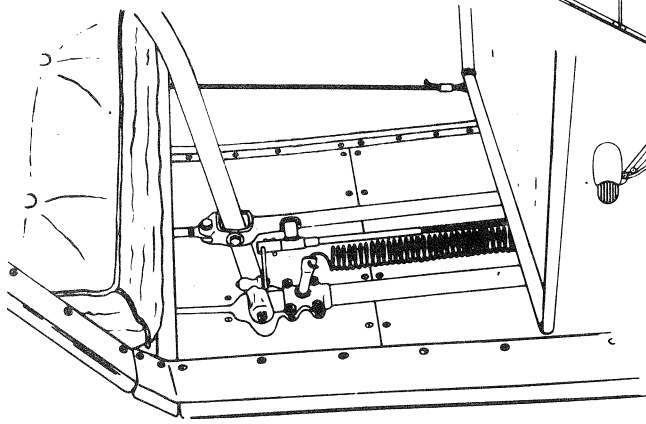
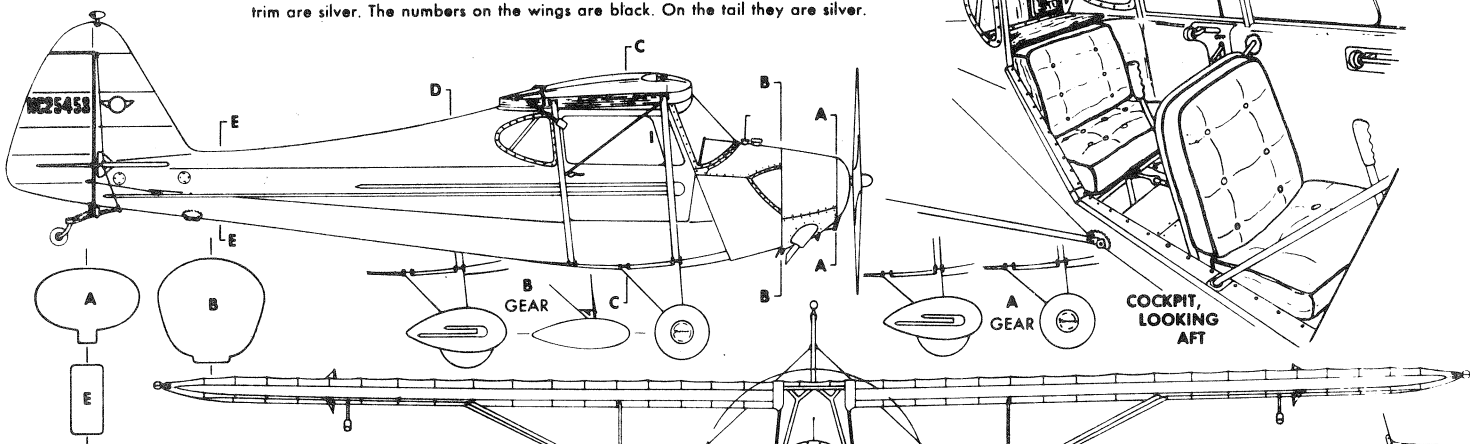

REAR COCKPIT FLOOR SHOWING TRIM ADJUSTMENT MECHANISM

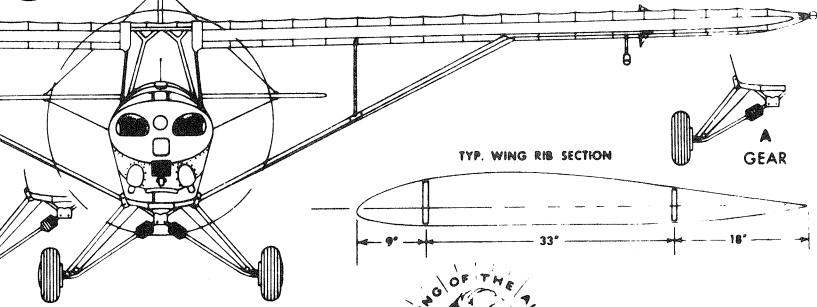

LANDING GEAR IN FLYING POSITION

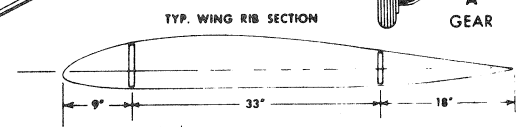

TYP. WING RIB SECTION

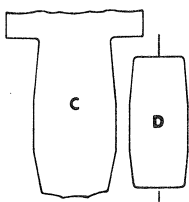

VERTICAL FIN DECAL

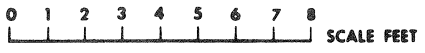

*Don Pratt*  
2/20/68