

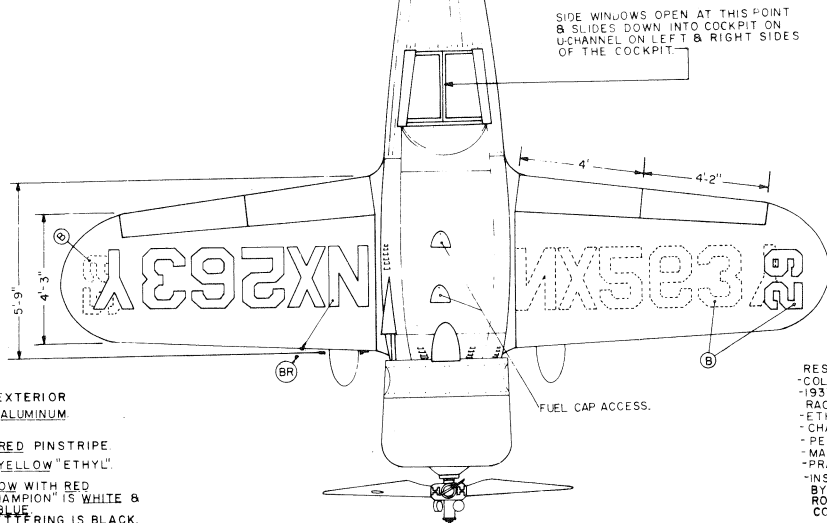

- MAIN PANEL OF MISS CHAMPION AS PHOTOGRAPHED BY K.D. WILSON.
- 1-BLANK
 - 2-RPM
 - 3-VOLTMETER
 - 4-FUEL
 - 5-OIL PRESSURE
 - 6-OIL TEMP
 - 7-AIR SPEED
 - 8-TURN & BANK
 - 9-CLIMB
 - 10-AIR TEMP
 - 11-CARB
 - 12-MANIFOLD PRESSURE
 - 13-ALTITUDE
 - 14-FUEL-AIR RATIO
 - 15-SUCTION
 - 16-SWITCH
 - 17-FUELIZER

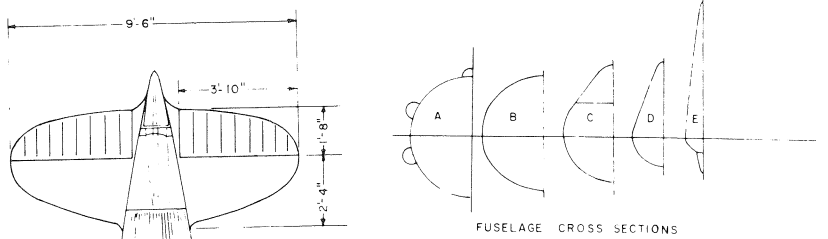

- MISS CHAMPION'S EXTERIOR
OVERALL COLOR IS ALUMINUM.
- (B) - BLACK
 - (BR) - BLACK WITH RED PINSTRIPE
 - (E) - WHITE DISC, YELLOW "ETHYL"
 - (C) - BASE IS YELLOW WITH RED PINSTRIPE, "CHAMPION" IS WHITE & BAR IS DARK BLUE
- ALL OTHER LETTERING IS BLACK. PLUG IS WHITE, BLACK, YELLOW, RED.
- MISS CHAMPION'S COCKPIT INTERIOR COLOR:
ALL METAL-ALUMINUM
DASH-BLACK
FABRIC-TAN.

- RESEARCH INFORMATION:
- COL ROSCOE TURNER
 - 1937-38-39 THOMPSON TROPHY RACE RECORDS
 - ETHYL CORP
 - CHAMPION SPARK PLUG CO
 - PESCO PRODUCTS
 - MACMILLIAN OIL CO
 - PRATT & WHITNEY INST ENG SWB2
 - INSPECTION MEASUREMENTS, PHOTOS, BY KENNETH D. WILSON AT THE ROSCOE TURNER AERONAUTICAL CORP, INDIANAPOLIS, INDIANA

**COL. ROSCOE TURNER'S
THOMPSON TROPHY RACER,
THE TURNER SPECIAL**

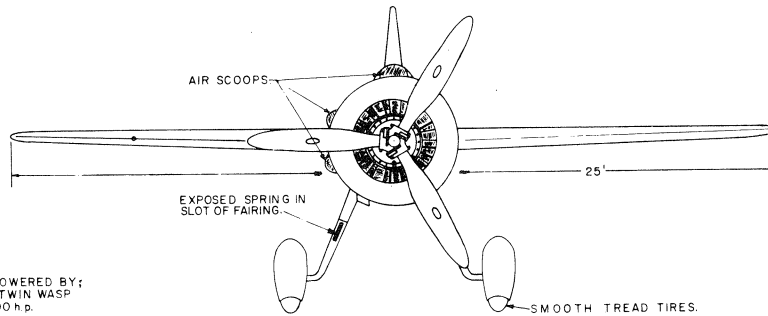

MISS CHAMPION IS POWERED BY:
PRATT & WHITNEY TWIN WASP;
S1B3-G ENGINE, 1000 h.p.

MISS CHAMPION IS DISPLAYED AT THE ROSCOE TURNER MUSEUM, INDIANAPOLIS, INDIANA, DEDICATED TO AMERICA'S TWO GREATEST AIR RACES, THE THOMPSON & THE BENDIX.

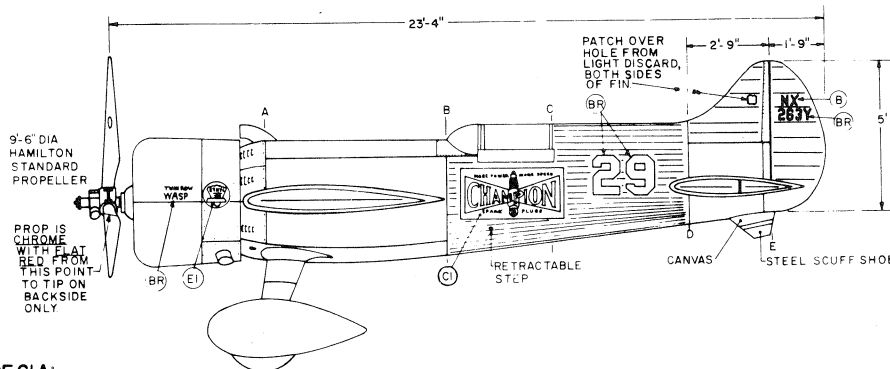

TURNER SPECIAL
THOMPSON RACE RECORD;
1937-RING FREE METEOR
3rd place- 253.802 m.p.h.

1938-PESCO SPECIAL
1st place-283.419 m.p.h.

1939-MISS CHAMPION
1st. place-282.536

DRAWN & INKED BY:
Kenneth Don Wilson
EAA 44170-AMA14065
19 MAY, 1969

